

lace-making, etc...that each one would do according to his taste, for his own satisfaction and own personal perfection, for the purpose of aesthetic decoration or for selling it for the benefit of the community.

(Editor's Note: After having examined these matters and meditated on this program, the Maestre thought that this property that we now own is insufficient to compensate the duties that the residents are assigned to, and to satisfy the degree of freedom that they deserve and could be practiced at will; reading, correspondence, meditation, prayer, personal works that require silence and solitude. In order to fill the gap, the Maestre has just bought a second property adjacent to the first one which will be organized in a slightly different manner. The first one will be reserved for collective use, for life in common, with swimming pool, space for sports and physical education, a pleasurable garden, a laundry, kitchen, as well as activities of an intellectual order, conferences, lectures and classes. The second property is being destined for works and occupations of a more personal and more silent nature, with a library, a place of rest, individual cells where everyone would be able to come to meditate, and an olive garden has been planned, trees of Peace, in order to enforce the necessary calmness and serenity. We don't have to think that only single men and women would come but also couples and families so we have also thought that this should be a more withdrawn place and particularly suited for children who should play and jump without their yelling and games bothering anyone. At present, a new educational system is being studied with the orientation of making these children complete beings with healthy minds.)

Herein lies an immediate plan of action, the purpose of which is to prepare the people of the New Age, a work we ask you to reflect upon, to become interested in and to convey your opinions, manifesting to us your criticisms and suggestions, helping us materially if you can, and with your prayers if you have understood the magnitude and nobility of its purpose, with the aim that this ray of Brotherhood may grow, comfort and enlighten all of us.

The ideas presented here are neither new nor personal. They have been announced by all the Sacred Scriptures, from time immemorial, by all beliefs and by all religions, whatever their origins may be and with whatever later deformations. Presently 80 million human beings who have searched for the Light, are in agreement recognizing in present times the end of an age, characterized by the "difficult times to come" (II Timothy, ch.3, verse 1). Nevertheless an idea so close to the Truth should not be destined to remain as a subject of conversation or lecture. In order for this idea to be productive and to bear fruit, it needs to be applied to the practical and material life upon which we depend so closely.

It should be noted that for a hundred years the cataclysms, wars, epidemics, and morbid psychoses, have created "barriers" in the human family. On one hand there are people who regard these catastrophes from a personal viewpoint attributing them to economic,

political, or social causes, and on the other hand persons who have tried to penetrate into the fundamental causes and who place the problems on a cosmic scale, so to speak, perfectly realizing that we do not make events rather we endure them. This is the cause of all the anguish and suffering, of evil, and of the apparent injustice that bind humans. Without being able to answer these disturbing questions, people are searching, nevertheless, for a solution and the only means we can employ for this type of search is comparison with the past; at which moments in history we underwent such crises, what characteristic signs accompanied them, what happened to the civilizations and nations who suffered them, how did they react, and whatever happened to them if their understanding came about too late? There are things which require long explanations, but that is not our intent here, although we will try to grasp its mechanisms, and afterwards it will be easy for us to establish a parallel with the state of our civilization.

It should be noted that the empires and nations that have dominated the ancient world left us noteworthy events (historical, administrative, and civil dates) as well as their heroes and their mythology. And we very conscientiously select, classify and learn in official schools only the teachings of the first part. We make an official science and we then reject a priori all serious attention to mythologies, that are defined by members of the academia as "simply fabulous stories whose interest lies particularly as an object of classical erudition". However, these indo-gangus, meso-persian, egyptian, greek and latin empires were governed by priests, and no important decisions were taken without consulting these Schools of Initiates. These monarchies were subject to the authority and wisdom of the priests, of which the king was, very often, the pontiff or at least the First Disciple, and all their sacred science has been transmitted in the form of heroic and mythological acts. In these countries, a phenomenon always repeats itself and its repetition has called our attention; that the decadence of their civilizations starts from the moment that the religious idea and the religious guidance are excluded from power. The first to be relaxed are the moral principles; not being subject to fasting, ablution, abstinence, internal discipline rules, the mores very rapidly get corrupted. Little by little, balance and the spirit of wisdom abandoned the people and their leaders; nations were at war thus undermining the stability of the economic and social order, and in a short time the material and social, intellectual and spiritual strength that led the world at the time was shattered, widely opening the doors to military invasions. Without moral defense, without the pointed finger indicating the temptations, psychosis took over the collective soul of these countries.

And aren't we watching an example of this type in Europe, the East, and a whole part of Africa?

"But understand this, that in the last days there will come times of stress. For men will be lovers of self, lovers of money, proud, arrogant, abusive, disobedient to their parents, ungrateful, unholy, inhuman, implacable, slanderers, profligates, fierce, haters of good, treacherous, reckless, swollen with conceit, lovers of pleasure rather than lovers of God..." (Timothy II, ch.3, verses 1-5)

We have believed that the needs of man are limited to its material manifestations, and for that, all aspirations for an aesthetic, ethic, and spiritual sense have been specifically erased from the concerns of the national leaders, without realizing that this is a real mutilation. And we are surprised at not being able to live in the true sense of the word. Life always responds in the same way when we endeavor to substantial transformation without consulting her; she weakens herself.

This is exactly what is happening in today's world. Not benefiting from the experience of the past, we have cut, unscrupulously, all the religious and internal life of our existence; the mysticism of ancient autocracies and theocracies has been eliminated leaving an emptiness that we do not know how to fill and in which all the viruses that cause our deaths find lodging. The first thing we have to do is to become aware of our dignity as men, as Sons of God, with all the rights and duties of such a state. Let us not betray anymore our origins and our garments of Light; we cannot continue living in such conditions.

After all these terrible and sorrowful years in which we have lived and continue to live, many people are coming to realize that we are atrophied and that our evils come from our lack of religion. Many individuals feel the impossibility of reforming the whole world and of bringing to it a more sane consideration of things; these thinkers attempt to save themselves by joining groups in search of the spiritual and of Universal Brotherhood. But each one of these organizations work in darkness, in silence, in search of the Truth, but without trying to multiply it. The time has come for the forces of the spirit to retake the place they are entitled to in the life of men and to reestablish the balance destroyed by our excessively material civilization. It is necessary - in an urgent way to make all sects abandon dogmatism and a certain religious fanaticism that more or less limits them and to make each one of them return to the purity of their primitive teachings, teachings that have slid to this land that is not their place.

In such a state of affairs, we are forced to conclude that the teachings are all the same, and that everywhere, Buddhists, Mohamedans, and Christians, with all the sects and sub-sects to which these great teachings have given birth, preach the love for one's neighbor, the love for Truth, selflessness, the purity of thoughts, words, and actions, the paternity of God for everybody, the possibility given to every being to be born anew and to respect the divine spark that is in him or herself and all the other fellow humans; his brothers and sisters. The time has come to expose all Truths, and to make them govern humanity. It is the spirit; it is the adherence to the spirit of Universal Brotherhood that the New Age, the Age of Aquarius, brings forth. And the spirit of fusion of the Aquarian Mission sees all teachings, already existing for so many years, materializing and enriching themselves with new forces in order to prepare the humanity of tomorrow.

The times of underground teachings, full of unexplained mysteries, where the light was carefully sieved, where all instructions took

the appearance of morbid occultism, have passed away.

The Aquarian Mission is not a new religion; it is the return to the One Religion in its essence, whatever its philosophical, cultural, or initiatic forms be, which its apostles have used to make a glimpse of it visible to men according to their age ( their degree of cosmic progress, their experiences, their degree of understanding and evolution).

The New Age (Aquarius) brings forth the dissolution of crystallizations that were in the long run transformed into dogmatic, fanatic, and intolerable ones. Now the great prophecies are being fulfilled; the age of Aquarius is characterized by the clarification and the explanation of the mysteries that were up to now taught in a veiled and symbolic way, a conciliation between the spirit and the word, for an inductive and deductive instruction, for the spirit of synthesis that follows analysis, for the balance that matches the intuitive, imaginative, the sensory ways and the ways of reasoning, deduction, and scientific and mathematic positivism.

This program is not a new one and many international organizations are collaborating with the Aquarian Mission whose hierarchy does not represent a sect with its partisans and sympathizers. The Aquarian Mission has existed for a long time in a lethargic way, so to speak; its manifestation was but symbolic, latent. The moment has come (because of a cosmic influence, an astronomical law) for it to take a material form, a tangible existence. For a long time now, the spirit of Aquarius reigned in millions of individuals and the Supreme Council for Spiritual Guidance has prepared, with the help of its organs and vehicles, the Instructors for the New Order, for which the UNIVERSAL GREAT BROTHERHOOD requests the collaboration of all sects, movements, and esoteric groups. The Agnostic Catholic Church, the United Christian Church Movement, the Free World Association, the Grand Council of the World Buddhist Church, the Movement for Buddhist Spiritual Rebirth, the Bahai Movement, the Sufi Movement, the Society of Silent Unity, the Universal Institution of Rosacrucians, the World Masons Association, the London Spiritualist Alliance, the Western Order of Rishis, the Universal Brotherhood (Neo-Pythagoric Institute), the Cavalliere della Pace, the Eastern-Western Spiritual Renaissance, the Knights of the Modern Grail, the Chinese Spiritual Center, the True Order of Anagarika, the Liberal Church and almost 200 other organizations join in the Universal Spiritual Union that has given the thrust to the New Age that has just materialized the Order of Aquarius.

The Mission of Aquarius strives for a new humanism, inherited through the channels of all gnosis, and philosophies of the spirit of wisdom and science; a humanism characterized by a principle of the meeting of all sources of practices, and the respect for all beliefs, of universality, where the strength and value of each one will serve the whole community for the benefit of all, in order to avoid selfish and egotistic appropriations of benefits acquired on the material, intellectual and spiritual planes.

The Aquarian Mission constitutes itself as a community of free souls of good will, with the purpose of world reorganization so that all men learn how to live, according to the conditions imposed by life itself, that is, in the spirit and in truth, in search for inner physical health, and clarity of internal detachment; in a word, to live cosmically, integrating oneself to the work of the whole Creation, where it is more necessary knowing each gear is good enough for the good progress of the whole group. All the political, economical, social, financial and language limitations are obstacles for the development of real man, for the cosmic entity that is in us. We need to live with the Universe and not against it. If we have to control it, we have to overcome it, and to overcome it, we have to still live in it and integrate in it.

The Aquarian Mission endeavors to make the New Age known, and to participate in its establishment rising above all philosophic and religious concepts, in order to bring them to a more real Brotherhood in an understanding and an equal love of one for all and all for one. The Mission of Aquarius does not meddle with any sect and is not opposed to any worship. All its spiritual program is summarized in a collective effort for the regeneration of the human species, with the wide purpose of solving the great problems of life with the aim of obtaining a complete and harmonious development of values that give the human being all its nobility; it is, in synthesis, the accomplishment of an action.

What is left is to establish a material program to fulfill such a spiritual realization. Thus, we are establishing the first spiritual community in Venezuela, near Caracas. A farm has been donated to the Missionaries to establish a first naturist center, open for all those who wish to live there permanently, or for a period of time. The establishment of several communities similar to this has been planned in several South American countries, to create a spiritual route all along the American Continent, wherein the regenerative fire of the New Age of Aquarius will enlighten the world during the 2,000 years to come. The life in these communities needs to be such that it will support and feed the adepts living there. Individuals are dedicated to a craft or intellectual activity to bring originality and diversity to their communal life. Several hours of the day will be dedicated to the study of religious, ethnography, philosophy, magnetism, symbolism, and esotericism, in order to create Instructors, who can pass on to others the meaning of the Aquarian Spirit, of the New Age.

All the organizations, sects, institutions, syndicates, who believe in the supremacy of the spirit and are interested in our work, are fraternally invited to give us their impressions and suggest their ideas. Their absolute independence and autonomy is guaranteed; we do not seek to convert; we are only trying to form a luminous ray of all the parts of the truth that are spread in all religions; we want to give an example of discipline and impersonal work for the benefit of a higher ideal. Impersonal does not mean like a robot, rather, it is the utilization of efficiency, the individual note in benefit of the community, the personal character at

the service of the collectivity. The whole world is presently in a whirlwind of forces that clash in destructive chaos and humanity suffers from uncertainty and a malaise that impedes its flourishing. Only Love and Universal Brotherhood can destroy these chains and save the world. It is in that spirit that the Aquarian Mission makes a call to all the beings of good will who have understood the dangers we are undergoing, in order to build a dam, with all our dedication, our sincerity, love and brotherhood, against the negative forces of hate, of personal interest, of evil in general, with the sole purpose that the marvelous message of Christmas be fulfilled in all its scope: "Glory to God in Heaven and Peace on earth to men of good will."

### THE FAMILY CELL

#### ITS DISINTEGRATION.

Whenever there appear crevices in a building, it is of no use to disguise the cracks by filling them up with plaster and painting them. The thing to do is to examine the entire construction, checking the firmness of the angular stones and replacing them if necessary. Once one has strengthened the base, there is ample time to attend to the aesthetics of the facade.

Today we are witnessing a critical moment: the stupendous disintegration of a whole civilization. Precisely at the end of an Era and the dawning of the next there is a transition period that disturbs the very foundation of the existing social structure. Religious and social movements suffer deep transformations in their outer forms every 2,000 years approximately, and these changes are responses to the retrograde movement of the equinoxes as they place us under successive evolutionary influences. We are living now in one of those periods of transition, one which is also presenting itself within the life of every man. It is a time in which one needs to concentrate all one's energies in order not to lose consciousness in the midst of the whirlwind.

Shall we allow our civilization to be stranded because of our inability to adapt? Or shall we probe into the ulcer to save whatever may be saved? We have seen political parties, governments and gigantic social and economic organizations undermined by destruction and corruption from within. Still we persist in attributing all this to causes which we associate with the external order of things such as hunger, bankruptcy, poverty, the chaos of war, political conditions and the like. In actuality, all these are effects, not causes. Already great prophecies have announced disorders for our age:

"BUT UNDERSTAND THIS, THAT IN THE LAST DAYS THERE WILL COME TIMES OF STRESS..." (II Timothy, Chapter 3, verses 1-5).

We need to examine ourselves sincerely to recognize that each one of us has helped to fulfill at least some small part of St. Paul's

prophecy. Do we not feel embarrassed by the description of such happenings? What have we done with that Grace of God which Jesus referred to in his reminder to the Samaritan woman? Not only do we lack the knowledge of what that magnificent Grace of God is all about, but we also impel future generations towards the same confusing life as our own, giving our children no real intellectual or moral guidance. The guidance we offer them is of a false nature because our generation has already lost the sense of Truth, and the meaning of words, and we can no longer see the Great Lesson being given throughout all creation. We have established our civilization on hierarchies of limited groups; unions, factories, offices, and clubs, and have put aside and rejected the very foundation of the one that is the most important: the family cell.

Study of the Old Testament brings one to knowledge of what that family cell consisted of: the father, the mother, the children, the grandparents and the servants. Whenever the father's guidance was recognized as particularly wise, then a nucleus was formed with brothers, sisters, nephews, nieces and cousins coming together with all their children, thereby creating a tribe. There have been a number of tribes which became famous and persisted over several generations, by virtue of their organization acquired through discipline and justice. The discipline was usually severe, and included obedience and respect from the children to their parents, with all things resting on dignity and the value of human life.

At present, the task is not to reestablish the father's autocratic power over all the other members of the family. The solution is not to turn backwards, because the New Aquarian Age will bring along its own social form. The family will probably be very different from what we see all around us now. As long as we remain in our present state of extreme individualism, the most urgent duty is to learn from past experiences in order to prepare the future and give our children a higher intellectual and spiritual education, preparing them to face life's conflicts with the capacity to work them out in an intelligent and appropriate manner.

The family cell is the angular stone of our society, and we need to improve its solidity as was suggested in our example of a cracked building. Once it is re-established on solid foundations, then there will be time enough to spend in determining the best social system to be adopted. At that point this will come for all in a natural and harmonious way.

The Aquarian Mission does not here intend to give out an entire course on child education. Rather, we want to emphasize the importance of our work with children and our attitude towards them.

Above all, one needs to see the children from an objective point of view without any personal feeling as beings who have incarnated on earth, neither for their pleasure nor for ours, but rather in order to continue their own evolution. We must recognize the same in children who have no family so that they may be adopted. This must be done by families of the New Age and also by those

following the Initiatic Path to serve as residents of an Ashram in which families with children are gladly welcomed so that the children may be educated according to the new Aquarian principles. It is not a matter of right or wrong upbringing. Rather, the point is to "bring them up..." We must cease to be useless vehicles and start preparing them for the battle they need to undertake, emerging victorious in time.

A double exchange between parents and children can already be foreseen. On one hand there will be discipline and education which is well reasoned and based on knowledge, and on the other hand, obedience based on trust and respect which is inspired by dignity. This objective point of view need not be in opposition to the subjective spirit expressed as personal love, so long as this sentiment does not represent an obstacle and is used correctly.

There is always enough said about the duties of children towards their parents; one must also recall the duties that parents have towards children. Consider whether the present alienation and defeat experienced by children and teen-agers is not caused by the failure of parents to fulfill their most elementary duties! We must realize that a child regards the decisions and pronouncements of his parents as the very SOURCE and unity. An adult may search for testimonies and proofs all about him, but the environment of a child is limited to the circle of people who live around him and he expects an absolute truth to unfold from everything therein. Children should not be deceived about anything, particularly in reference to their parents. Every child has the right to experience disappointment, and as life continues on he shall be disappointed to find out that his parents are only one stage on the road, and that he is another point a bit further advanced with a gap that increases in a uniformly accelerated motion. Nevertheless, those in the position of parents do not have the right to disappoint their children; everything is owed to them. From the moment of acceptance of a mission, an apostleship of educator, one must fulfill it and fulfill it well, otherwise it should not have been accepted at the start.

Usually, the education of children is limited to the mundane life. In most instances, this is in direct opposition to their inner nature. In other words, the effort tends to be placed in the periphery, and in their relationship with others. This works out more or less, but in most cases the child is not awake to his or her sense of self-worth. We have all seen the evidence of destruction reflected in the laugh of teenagers who lack understanding of Life. Let us start to accustom our children, starting from the first seven years of their life, for example, to follow a strict obedience, with neither severity or weakness, but with balance, to correspond to an established law which we do not expect will change. During this period of their education, we must satisfy their minds with explanations at their own level which need not be false on that account. If we do not allow children to lie, why should we have that right? To simplify an explanation does not mask the truth, and while simplifying the facts, we must nevertheless maintain their reality. Our children shall reflect on what



they have been told, perhaps unconsciously, and this shall serve them as a springboard. It is not only important to teach something to children, but also we must be able to form spirits ready to observe and to reflect, to analyze, to research, and to love the Truth. "There is nothing more beautiful than Truth" said Boileau. Let us nourish spirits capable of synthesis. Analytical, narrow and small spirits, those who are specialists in minute and silent works are numerous, and their time is passing away. The New Age shall emphasize the research of synthesis and we shall be in need of ample, strong and capable spirits who may understand a system as a whole. This capacity is also of utmost importance in the formation of character during childhood.

We have been nurtured in a civilization which does not fit us; it is already in the process of dying and it is dragging us along. Let us allow this gigantic sinking to take place without us, centering ourselves in order to save the best of it by creating in our children a pure, strong and clear-sighted humanity for the future world.

### LIFE IN THE ASHRAM

We have outlined in the previous Message the material organization of life in the community and of the resources which it has at present. Our first concern was to assure that practical life, as it also corresponds to our physical life, but now we are in route to the intellectual and spiritual instruction and the daily program requires several hours of inner work, of perfecting and elevating each one.

Generally, by the word Ashram is meant the encampment where the Guru lives accompanied by his disciples. When he lives alone, the Ashram takes the name of Kutir. Thus, by the meeting of the chellas (disciples) around a Saint, and ascetic, a Yoghi, a superior life is organized; the community acquires well-defined rules that are traditional in the existence of Ashrams. The sanskrit word, ashrama, defines a way of living, a state of existence, a stage in the Path to Realization, four ashramic degrees of realization a man need achieve during his terrestrial incarnation:

a) Brahmacharya, the one devoted to God through study and the practice of the disciplines, among which abstinence is the most important.

b) Grahestha, the household stage, giving the teachings to the spouse and children and practicing the ceremonial.

c) Sannyasa, the one who realizes renunciation, self-denial in all virtues, the pilgrim life (dressed with the Holy Gerra, a yellow-red piece of material, of saffron color), the perfecting in the Yoga path to achieve in one instant the final liberation.

In brief, the Ashrams are the sacred places wherein the science of life is learned, the place for the preparation of Wisemen.

They are numerous in the East, especially in India, and for some years they have started to be established in Europe and America. They are not convents or monasteries, even in the case of Ashrams for only men or only women; rather they are generally co-ed and the education is extended to even the children on the more perfect ways to ascend spiritually, intellectually, psychically, and artistically. The number of dwellers reaches from a dozen to five hundred, even though, generally, not so many are admitted unless they are children.

The use of time in the community starts with physical exercises at sunrise. When the night leaves its place to the day, a moment of relative calm is produced; at this moment the body manifests the same tendency towards rest. We have to profit from this natural condition and practice all the exercises. It is not only the case of training with the aim of strengthening the muscles, even though this goal is praiseworthy and very good in itself, for our body is the vehicle of the spirit, our working instrument, and the first requirement for inner health is to maintain a healthy and vigorous body. During the 20 minutes that this physical exercise lasts, the spirit is not passive and at this moment assimilates peace and serenity for the day that starts by making contact with the cosmic forces represented by the first ray of the rising Sun. One then very easily realizes the cosmic role of man, of the need he has, for his own good, of identifying himself, as much as possible, with the Creation in a very personal way, in the most profound way. This first action provides to everyone, the necessary attunement required for the accomplishment of his daily work.

Immediately after having made contact and harmonized with the Universe in the process of our organic life, the Cosmic Ceremony reminds us that we are all children of the one God, that we are here to glorify Him, to dedicate Him, the day, to make resolutions of Peace, Harmony and Love to our neighbor, as well as to oneself; in this way the process of the soul is found directed in a more strict sense every day.

Thus these first two occupations tend to make the mechanism of intelligence and inner life function.

From 7:15 to 11:30 a.m., practical arrangements and the material life have to be taken care of. On the one side, the administrative organization with correspondence, literary works, the formulation and planning of projects, and on the other side, domestic work, maintenance, gardening, finances, etc...

At 12:00, after the bath, the Yoga practice interrupts the adepts from their respective duties, and the "asanas" (special postures that strengthen the psychic centers) are practiced in silence; the asanas attempt to establish an elevation, a point of contact with the One Principle in search of the liberation of the soul and the amalgamation of the "EGO".

After lunch, a period for a siesta is assigned until 4:00, time used by each as they like, be it to rest, to read, to take care of personal matters or to relax in the way that is most convenient to each one.

Three hours of study and progressively applied exercises of a well-studied program follow; this study could be based on a course given the day before, thus facilitating the complete assimilation of the teaching, or else, preparing the teaching so that everyone will be perfectly aware of the intellectual effort that should be offered. The half-hour for a light dinner barely interrupts this research interval that proceeds until 9:00 with a group teaching, be it philosophical, astrological, orientalist, of symbolism, esotericism, or even of general cultural education. All these studies are provided preferably in a conversational manner, in which all the questions are answered. It should be very well understood that all these studies are the supporting base of the structure upon which is built the spiritual and inner life of the soul.

The only required condition to live in the community is the eagerness for our inner perfection, the need to liberate oneself from the external influences that govern us. It is necessary to apply the famous proverb, which, by the way, was not quoted by Socrates but rather by Chillon: Know Thyself, to know what equipment we can count on, what difficulties and what possibilities we have, and on what defect we have to concentrate our forces. All that knowledge of oneself, and consequently of others, is provided by astrology that every adept need study with the aim to know where he comes from, where he is going to, and thus escape any paralyzing sentimentalism.

The YOGHI is an ascetic who has arrived to Wisdom by the Union of the incarnated soul (Jivatma) with the universal soul (Paramatma). Even though this way is purely meditative and contemplative, to arrive to it one has to acquire an absolute control over the will-power, to be full of knowledge and the active principle.

YOGA, which literally means Union ( sanskrit root, Yug, which means conjunction, bond) comes to the unified Homology, and to arrive to it, the practices bring forth the destruction of thought-sensations and the development of the spiritual faculties of Man. These practices do offer some dangers (above all for the people who believe that this consists in rhythmic breathing or practical retention with no previous training) but are practiced in the community under the guidance of the Master, in person, who does it with causal knowledge for the development of the Plexus (Chakras) according to the level of each adept.

Since all the Science of Yoga consists in the balance between the Macrocosmos and Microcosmos, it is, in no way a coincidence that the Order of Aquarius incorporates this branch of orientalism in its practices because it consists of an Identification of Man with God.

## The Cosmic Ceremony

### Religious Viewpoint

From the viewpoint of ceremonial aspects, the Cosmic Ceremony is a session of Magic (understood in the etymological sense of MAGISTER, mastership), that is, an act of white magic as are all masses. Nevertheless, this ceremony is enfolded with greater power, more than ordinary masses, due to the fact that it is based on cosmic powers. Cosmic powers are the expression of God Manifested, that is, Nature. It is of greater interest than other masses because it can be attended by people from diverse concepts. It can be regarded as a mantram of celebration of a neutral kind and uses formulas already accepted by many doctrines. The prayers used by the attendants can be chosen by themselves according to their own creed. This is truly the Primitive Religious Ceremony which lacks only the many varied decorations added to it by different Sects throughout the Ages. It would be fair to describe it as a scientific act based on deep architectural knowledge. The spiritual sense of it is balanced by a brief ritual so that morbid imagination will not take over or distractions of all sorts which arise whenever a ceremony is too long.

This ceremony was practiced in the Aztec Sanctuaries, in the Mayan Schools, among the Atlantis, in the Convents of Ancient Initiates and at present is the one to be practiced in every Aquarian center, while the family heads become true disciples of light and ready themselves to worship in their own home. Although having small variations, one can say that this is the same ceremony used by the Essenes, the Nazarenes, the Disciples of Christ, the Druids, and the Celts. The purpose of the ceremony is to elevate the Spirit.

In the ceremonies of High Theurgy the secret forces are used by the will of the Magician, always for the good, and in this particular case, these forces are used for the well-being of Humanity. This force is the Christic current which when used in collaboration with that of the attendants can be radiated to the immediate environment and also may remain in the Temple. All the attendants become recharged and at the same time can transmit a very subtle vibration. This vibration, this charge, is a sense of well-being, it is the magnetism of the Christ.

The great masses of East and West will find good news with the return of this Ceremony which is expressing the New Age, wished by so many and which can please all religious denominations. The fundamentalists will find the reading of the Bible, the Catholics, their own chants and prayers; the Hebrews, the Verses of David; the Occultists will notice the fundamental mechanism, the primitive Christians will enjoy the direct communion, without any agent; the Platonic philosophers will fully understand the formulas to the Demiurge; the Pythagorean will be pleased to see the numerical succession and asymbols; the Shintoists will enjoy the ritual itself; the Buddhists will recognize their own candles, incense and figures; the Mohammedans will find the postures of worship familiar. A gesture, a prayer or a symbol remind us of an important aspect of many religions and doctrines.

The Sanctuary is the Sacred Temple where we pray and it is the symbol of our own body as the Temple of the Spirit. Matter covers up Spirit and when we enter a temple we therefore attempt to unclutter our Spirit, and the positive contacts the spirit. Woman as a negative pole would cover up her head in the Age of Pisces to avoid contact and in this New Age she is searching the Spirit of High Initiation and is beginning to receive the spiritual magnetic currents from the Highest and this is why in our Sanctuaries she also enters with head uncovered. All attendants enter barefooted to have greater contact with the Earth and therefore establish a spiritual current of true Purity.

Attendants are asked to become active by elevating themselves internally and surrendering to God so that it may also serve as a true meditation. Unfortunately, up to now, many people have been used to attending their own mystical ceremonies of their affiliation without knowledge of its importance and without knowing the behavior demanded at different stages to attain true inner harmony.

We are now living in an Age of Knowledge (TO KNOW) and everything which remained occult shall be revealed. These ceremonies fulfill very deep purposes which are necessary to inner life and their mechanism is of an esoteric nature, to sublimate the subtle forces of life in order to elevate ourselves towards the Divine. Once this knowledge was lost, the rituals fell into mere formulas lacking substance for the most part. All expressions of life from the birth of the seed to the dance of our planet around the central fire reveal a wise ceremonial sense, and the set of all ceremonials form the quiet ceremonial of the universe. This is the seventh aspect of universal life: The Ceremonial. One needs to develop the seven aspects to attain balance and the ceremonial need not be any more a mechanical and empty practice, but rather an inner elevation of the individual consciousness towards the universal consciousness, an intimate communion with God, Universal Mind, Intelligence Principle or whatever name we give that superior entity.

In the New Age, when the Study Centers, Initiatic Schools, and Ashrams are established, one will also find that the head of the home, having acquired an initiatic degree will be also in a position to perform the Antennae even though not a priest himself. In this manner he will attune himself to all the secret temples which now when there are no mysteries are Sanctuaries of The Universal Great Brotherhood.

Whenever an Antennae is performed, the attendants need to tune in mentally with the Sanctuary. This can be done from different homes, which then become attuned to the same type of vibration. This vibration has no limit. Whenever one meditates here on our planet, one begins to vibrate and become attuned to all those who are also meditating and unified. This is the type of contact we shall have for the future in our planet, through which all can become one, no matter what the different religions.

The priests of the Aquarian Mission are INITIATES and are called priests because all those who participate in an act of magic or ceremonial are called thus. The Aquarian Mission calls them priests

even though we are not a religion, rather we are attempting to return to the original religion, the only one, to the Worship of the Father; in Spirit and Truth. Jesus said: "The day shall come when the Father will be worshipped in spirit and truth". This is what we are here for, to ask all religions to put aside antagonisms and personal interests and unite, rather than to create a new religion. We can see the return of spirituality because the vibrations of the Temples are elevating and bringing the peace to a world that had completely forgotten it. Many thought that people would forget about God after the World Crisis but the contrary has occurred. There has been so much misery in the world that Man has finally understood that he had reached the bottom layers of materialism and therefore felt the need to ascend towards God.

All magic ceremonies require accessories of 4 types: luminous vibrations to produce flames (candles); ethereal vibrations to modify the environment through its perfume (incense); a fluidic contact to act as the tip of a metal antenna which collects the waves, and fluidic condensations to accumulate the energy (liquids such as water or oil). The place chosen as well as the robes of the priest are important. The priest's robes are white with golden thread at certain places. The candles act as guardians of the invisible which prevent inferior spirits from participating in the ceremony. The ablution of the hands is also a magic act to release negative fluids. When the altar is incensed, it is being purified together with the surroundings to aid the mental radiations and prayers to elevate to God. The water is consecrated magically and magnetically. The open palms of the Priest during the Divine Service have been also consecrated and are charged with a powerful fluid which they emit. The altar has 4 elements: fire (candles), air (incense), water (a water chalice) and earth (soil from a Holy place, bones of a saint, etc.) The two auxiliary altars are represented by two columns, the positive and the negative of all Sanctuaries, the two magnetic poles which balance the temple and whose sacred names can be found in the Sacred Scriptures. In magic one uses even numbers where a material benefit is expected, but when one strives toward spiritual powers then one uses uneven numbers. This is the reason why the number of lights in the Sanctuary is uneven. Candles need to be white; the colored candles are also used to attain material benefits. True magic is the true control over science according to the ancient word "MAGISTERE" which means mastership, control.

An interesting detail to be noted about this ceremony is that it only lasts 7 minutes and besides its symbolic meaning it appeals to the attendants' patience. It is well known that once one enters a church or temple it is enough to pray a few prayers with all the power of one's soul. It is hard for many people to remain in long concentration and they get tired easily, finding other things to look at. This is how they easily forget about the holy ceremony and enter into "sin" or into a negative mood that does not benefit them spiritually anymore.

The number 7 is very important in its symbolism. It signifies the 7 states of matter and the 7 planes of evolution, therefore the

Ceremony practiced by the Aquarian Priest consists of 7 parts which also signify the 7 planetary vibrations, 7 musical notes and 7 colors of the rainbow. Also, the 7 years of human evolution, the biological cycles, etc. There are many other esoteric explanations about this number which we will not go into at this moment.

It is necessary to state that to practice the Cosmic Ceremony it is required that one be an ordained Priest and even though one may be an Aquarian INITIATE, one still needs a special instruction, a transmission of power, in order to have the right to practice it. This power is transmitted from Master to Disciple through a special training from the General Direction of the Institution, in addition to the INITIATIC DEGREE. All others will only follow the Ceremony and will not repeat the words used by the Priest.

Even though there might be no one yet ordained as a Priest, the members can meet and tune in at a distance to follow the Ceremony mentally and benefit from the magnetic radiation sent from the Central Temple of the Institution and other Sanctuaries of the Universal Great Brotherhood where the Ceremony is done in a perfectly organized manner. This gathering of the members is referred to as an "Antennae" and has a Guide who can be and INITIATE or not and who is in charge of mentioning the different parts of the mystical moment and who becomes like an assistant, at a distance, to the Priest. The guide only reads the parts which correspond to the attendants in the Temple or Sanctuary where the official ceremony is being held. The Guide prepares the Altar during the first part, prays the Prayer of the 33 TAUS and, not being a Priest yet, may remain silent for the following parts or start explaining each part so that everyone may tune in better with the Priest. Each day and at the precise time when the Ceremony is practiced by a Priest ordained by the Aquarian Mission, all others are enfolded powerfully by the spiritual ambience of the Temple or Sanctuary where the Ceremony is being held.

The Antennae is the psychic tuning and attending of the Ceremony, so to speak, rather than a pantomime of it.

The Cosmic Ceremony, as is the case of all masses and Ceremonies, can only be practiced by men. This has nothing to do with men being superior, rather it has to do with their polarity which would be a very lengthy subject to explain here. The antennae, on the other hand, can be guided by both men and women.

The preparatory stage before the beginning of the Ceremony on Sundays is an introduction to prepare the mind for an appropriate vibratory frequency needed to participate in the act in order to be most receptive to the spiritual vibrations which descend to the physical plane via the Priest who becomes the intermediary between heaven and earth during the sacred service. Everyone prays a Universal Prayer fit for the New Age, which is non-denominational and asks for all humanity at large in a selfless manner. Also, there is an Act of Faith where we all acknowledge our spiritual nature and a chain of brotherhood to invoke the presence of the Christ and to unite the hearts in due respect to Father, the

Creator and attracting thus the purest vibrations to the Holy Sanctuary. The mystical melody "Eternal Secret" is played on the organ and all this introduction prepares the attendants for the spiritual approach which is to follow the beautiful initiatic celebration. The prayers are mantrams, that is, powerful words with a creative force. The music harmonizes the surroundings and the incense cleanses the atmosphere.

The preparation for the Ceremony begins when the Priest, or the Guide of the Ceremony, in the absence of the Priest summons the people with three rings of a bell; leaving their worries and mundane preoccupations behind, the people enter barefoot through the door of the Sanctuary and take their places with peace and inner calm. Then the Priest or Guide, lighting the odd-numbered lights on the Altar, proceeds with the incensing, blessing the incense with a sacred formula; then he blesses the Altar and the Columns, raising the incensory before the Altar and saying: "Just as this incense rises toward you, God, so may our souls rise towards you to find Love, Peace and Universal Wisdom"; likewise he invokes the Holy Angels. Toward the Altar and the Columns and then toward the people he says "Incense to the Father, Incense to the Son, Incense to the Holy Spirit". Thus the Consecration of the Place is performed by fire which transforms the incense into delicate perfumed curls of smoke which rise silently and surround all the gathered souls with an atmosphere saturated with spirituality.

Now the moment comes for the people to cross themselves, right arm over left, and join hands to form a magnetic chain which radiates waves of light, peace and happiness. At this time the Priest says: "Master Jhesu said, I will return when the light appears and wherever two or more gather in my name, I shall be among them." He then recites the following Micro-prayer of the New Age: "Praise and Blessings to Thee, my benevolent God, may your presence be recognized by all beings on earth, and Peace spread throughout Humanity. Peace for all beings, on all Planes. Amen."

Now the people return to their places and, facing the Altar, they say in unison the Universal Prayer, following this with the Statement of Faith: "We believe God is LOVE. POWER. TRUTH and LIGHT. That a Perfect Justice rules the world. That everyone of his children will reach His feet throughout various Ways. We recognize the Paternity of God and Human Brotherhood. We know that we serve Him better by serving our brother Man. May His blessings fall upon us. Amen" The Priest says: "Good Morning. In the name of Christ our Lord I open this act. May his Infinite Love and Wisdom enlighten our Minds for the studies of His Divine Doctrine." The Priest then kneels before the altar and the sacred notes of "The Eternal Secret" fill the room, adding a touch of sublime art.

Now begins the ceremony proper of the Order of Aquarius; a true act of spiritual alchemy for the sublimation of our thoughts; the Ceremony is designed to appeal to all persuasions, all the way from scientists who can explain with their biophysics the reasons for the atmosphere that is created, to the idealists who can appreciate the fervor of prayers that are said in unison. Everything in the



Ceremony is said according to its origin; respect for the magnetism of the Word requires, for example, that certain prayers be delivered in Latin in order not to lose the vibratory force of this sacred language. The Ceremony is sacred and follows a strictly initiatic tradition that has always been respected by INITIATES and sacred centers. What follows is the order of the Cosmic Ceremony:

I. Prayer to the Demiurge (Universal Soul). This is designed to locate the devotees on a special plane; this prayer includes the letter "T" 33 times, each time in a key and powerful position, and for this reason it is generally referred to as 'The Prayer of the 33 "T's"'. Derived from the Druids, this invocation is not translated in order for it to retain its original magnetism, which is characteristic of the planet MERCURY (symbol of the Intellect and Celestial Messenger).

II. Consecration of the Priest. This is the moment in which the Priest, the Aquarian Missionary, lowers his voice in an act of humility and changes himself into a representative of the Divine; this is the real beginning of the Ceremony. The planetary symbol for this moment is JUPITER (God of the most benign powers and envoy of the Divine Wisdom).

III. Purification of the Place. The Priest takes water and pronounces the formula of consecration, sprinkling the water to the four cardinal points. The people use this moment to send out their thoughts to their friends, family, etc. MARS (symbol of energy) is the planet that characterizes this moment.

IV. General Consecration. The Priest now uses Latin, but the people can participate by saying the prayer in French, Spanish, English, or their mother tongue: "Oh Demiurge, we ask you to sanctify and bless this place and everything. May we receive the heavenly Dew and an abundance of the substance of Life and Earth. AMEN". The symbol for this moment is the SUN (Cosmic Energy).

V. Personal Prayers. A minute of silence is now observed while the Priest along with the entire congregation (each according to his conception), prays to the Divinity. Each person is in concentration in his own way. The Priest then gives the sign for everyone to join in the Universal Prayer. This prayer is said every day at the same hour (even by those who do not practice or attend the ceremony) in the mother tongue in various places around the globe so that a magnetic chain might be established. Upon the delivering of this prayer, many sick persons have regained their health; many down-trodden ones, reciting this prayer with faith, have reversed their fortunes. The MOON symbolizes this moment of intuition, passivity, and communion of the mental plane.

VI. Communion. This is the central part of the Ceremony, creating the strongest vibrations. The Priest establishes contact with the Cosmos and prepares the Communion. With a special prayer the Priest, an expert in theurgic mechanisms, displays his personal magnetism and gives off forces capable of uniting between the divine and the profane worlds. When the Priest turns toward the people, all kneel

down together with lowered heads in a passive state in order to receive these celestial benefits. The communion is the fluidic contact which unites man with the Divine, the magnetic ray which is the very vehicle that brings about this union; if we call it anything else we would be limiting it to a dogma. The Priest then extends his arms to the Heavens and brings them down in the form of the cross, simultaneously sending out cosmic fluid in all directions, an emanation of the Great Divine All; the people open their hands, the better to gather in these forces. Thus the people are united in this moment of communion, achieving a complete and total fusion; they concentrate on giving their powers to the one presiding, who in turn will transmit them to the sick, the infirm and those who suffer, giving faith to the afflicted; with this he illuminates the understanding of those who search for the Truth and emits fluids for peace in the world. Before returning to the common world the Priest is still in the divine sphere, present only by virtue of his visible, physical body; his individuality permeates beyond the terrestrial planes. Throughout the Ceremony the Priest is connected with planes other than the earthly ones, and the transmutation effected by his theurgic mechanisms is not understood except by those initiated into the knowledge of mental and psychic transmutations. Still invested with celestial powers, he pronounces his blessing and the people recite aloud "Let us glorify Christ the King and may the Aquarian Age reign". (The people of the East say: "We glorify the Avatar and may the Golden Age reign".) VENUS (Messenger of Love) is the planet which symbolizes this part of the ceremony.

VII. The Execration. This is the last part of the Ceremony and the people, who continue kneeling to receive the maximum benefits, give their attention to the Priest while he pronounces the formulas of execration over the objects of the Altar and over himself, thereby returning to the mundane world. The symbol of SATURN is found here, indicating the tests awaiting he who would return from the higher planes to the struggles of material life again.

On Sundays and Initiatic Holidays, two more parts are added to the Cosmic Ceremony in order to account for the discoveries of two new planets, Uranus and Neptune:

VIII. The Verses from David. These are the theurgic keys which correspond to the Genii and which introduce the Biblical fragments that have esoteric meanings. URANUS, the planet of abrupt changes which also rules the higher intellect and altruism, belongs to this part of the Ceremony.

IX. The Song. The people now sing in full voice a religious song to create an elevated atmosphere, and since this song follows the Communion, it should be one which allows the singers to enjoy the full mystical joy of Universal Union. The planet which characterizes this mystical moment is NEPTUNE because it is the planet of psychic phenomena, the astral body which opens the way to the etheric spheres and enables one to comprehend celestial music.

### Ceremonial Viewpoint

When he arrives at the Altar, the Priest begins the Ceremony with the word "PAX". He makes the salutation by raising the right hand with the four fingers extended (symbolizing the 4 elements, the 4 cardinal points, the 4 sacred words of the axiom: TO KNOW, TO WILL, TO DARE, TO KEEP SILENT) and the thumb folded in the palm of the hand to signify that the energy is being used for inner transmutation rather than for aggressive force.

Before going on with the Ceremony, the Priest reads three verses from the Bible, opening it at random to find the answer to the problem of the day (each person applies the lesson personally).

On special days (Initiatic Holidays: March 21st, May 1st, June 22nd, September 23rd, October 7th, December 24th, January 18th) an introduction is made to commemorate the occasion.

All daily ceremonies proceed according to the following ritual:

GUIDE: AUM TAT SAT

PEOPLE:

1) Prayer of the 33 taus. Prayed in its original form.

1) This prayer locates everyone present in a higher plane. It is a prayer transmitted by the Druids, but whose origin dates from most remote Initiations. It is the elimination of evil.

### ORAISON DES 33 TAUS

Oh, Demiurge, ecoute-moi.  
Demiurge Eternel, Demiurge Infini, Demiurge Unique.  
Force, Justice, Amour: Aide-moi  
Toi qui es flamme, Toi qui es Feu, Toi qui es Lumiere, Protege-moi.  
Toi, Substance spirituelle et eternelle, Etre Parfait  
Ingenere, Immuable, Qui est sans commencement, sans milieu et sans fin et qui eternellement s'engendre soi-meme...  
Toi, Architect Sublime, qui par l'effet de Ta volonte tire du neant tout l'univers  
Toi, Axe et pole du Cosmos, Infini, Eternel, Incree.  
Toi, Cause originelle et permanente de toute chose  
Toi, Ame et Stabilisateur des Mondes  
Toi, Maitre des entites des Trois Mondes  
Toi, Source inepuisable de vie et d'intelligence  
Je suis Toi-meme  
Je te vois partout  
Je te sens en Tous lieux  
Ton Verbe est l'Harmonie des mondes et des Cieux.  
Tu es TOUT  
Tu es la Vie, Tu es la mort  
Tu es le vide, Tu es le plein  
Tu es l'obscurite, Tu es la Lumiere  
Tu es le silence, Tu es le Tonerre.  
Tu es au-dedans, au-dehors, au-dessus- et au-dessous  
au centre et a la peripherie

Tu enveloppes l'Infini et l'Infini est plein de Toi  
Tu embrasses et Tu contiens TOUT  
Tu es le TOUT qui est UN  
Oh, Demiurge!  
Oh, Merveilleux Silence!...

2) GUIDE:

Consecration of the Priest. He pronounces his formulas: "Ego... sum Sacerdos Demiurgi in aeternum. Spiritu Luminus est in Spiritu meo..."

3) Purification of the place. Sprinkling towards the 4 cardinal points.

4) General Consecration: The Priest pronounces: "Adjutorium nostrum in nomine Demiurgi..."

5) Prayers. The Priest pronounces the secrets and personal prayers and gives the signal to pray the "Universal Prayer".

PEOPLE:

True beginning of the Ceremony. The people prepare for the purification.

People ask for their friends, relatives, etc. This is a moment to concentrate thought towards a chosen place.

People pronounce in their mother tongue: "Oh Demiurge, we implore you fervently to sanctify and give plenty of kindness and dignity to this house and everything. May we receive, Lord, the richness of the Heavenly Dew and an abundance of the substance of Life and Earth."

Each person, according to his/her needs prays. For those who do not need to ask for anything this is a moment of meditation. The Universal Prayer is said aloud by everyone. Its translation can be found in almost every language.

UNIVERSAL PRAYER

Blessed and Merciful God,  
Almighty Father of the Universe,  
Sublime Creator of all Perfection,  
Celestial Giver of Goodness and Mercy  
In this solemn hour when our heart is filled with Love,  
When Your Perfection vibrates in our Heart and we see you  
with the eyes of our Soul.  
We implore God, in the name of Christ our Redeemer to give  
Peace and Harmony to the World  
To end the suffering and pain of the poor on Earth  
and to make Life more abundant.  
That happiness may reign on both the material and the  
spiritual planes.  
Father, we pray that you bless our world and that  
peace may reign in the hearts of all Human Beings on Earth. Amen.

GUIDE:

PEOPLE:

8) This part is added only on Sundays and Initiatic Holidays. Reading three verses from David, according to the 72 Sacred Psalms corresponding to the Genii. The Priest pronounces the names in three intervals.

6) Communion. The Priest asks the Higher Planes for Powers: "Oh, Adonai, Tzebaoth, Ieve, Almighty Father, Creator..." Already in touch with the magnetic fluids the Priest lowers his arms in the form of a cross and pronounces "Daleth" (the sacred word asked for by the people). Turning towards the people he pronounces "Sanctus, Sanctus, Sanctus..."

6) When the Priest raises his arms the people say: "Father, I am unworthy of receiving you in my humble abode. But do say one word and my soul shall be Pure and Holy."

The people say here:  
"Sanctus, Sanctus, Sanctus...  
DOMINUS DEUS. PLENI SUNT  
COELI ET TERRA GLORIA TUA.  
HOSANNA IN EXCELSIS. BENE-  
DICTUS QUI VENIT IN NOMINE  
DOMINI HOSANNA IN EXELCIS.

The Priest immediately after the Communion gives his own blessings.

Let us glorify Christ the King and may the Aquarian Age reign.

During Initiatic Holidays and Sundays, the Priest turns back to the Altar immediately after Communion.

After the Blessings have been given, is the moment for the Song by everyone.

8) TANTUM ERGO.

Tantum Ergo, Sacramentum  
Veneremur cernui: Et antiquum documentum  
Novo cedat ritui;  
Praestet fides supplementum  
Sensuum defectui.  
Genitori, Genitoque, Laus et jubilatio;  
Salus, honor, virtus quoque  
Sit et benedictio  
Procedenti ab utroque  
Compar sit laudatio. AMEN.

GUIDE:

9) The Execration. It is the end of the Ceremony. The Priest pronounces formulas over the objects of the Altar and upon himself in order to return everything to the profane world.

The Priest ends the ritual and prays in his own name saying: "Thank you, God, for allowing me to serve once more the Cause of the Universal Great Brotherhood. May Your Will be done, and not mine.

The Cosmic Ceremony is not confined to the Order of Aquarius; this Ceremony has the same basis as the ancient and primitive Mystic Convocation.

Like the Star of the Masters (symbol of universal vibrations), this Ceremony is composed of 7 parts. The addition of the two extra parts on Sundays and Holidays makes 9 parts. The Ceremony symbolizes the Spring, which in turn, represents eternity; moreover, the nine symbolizes very well the religions which are being fused together through the process of the ages.

In its role as the vehicle of the Universal Great Brotherhood, the Aquarian Universal Mission waves aside all dogmas and ritual obligations; the Ceremony is simply available to anyone who feels the need to practice it. Thus persons who do not participate directly may follow the Ceremony from a distance mentally.

The Ceremony is presented in the following order:

1. Prayer to the Demiurge. (Introduction), symbolized by Mercury.
2. Consecration of the Priest (beginning), symbolized by Jupiter.
3. Purification of the Place, symbolized by Mars.
4. General Consecration, symbolized by the Sun.
5. Personal Prayers, symbolized by the Moon.
6. Communion, symbolized by Venus.
7. Final Blessing and Execration symbolized by Saturn.

On Sundays and Initiatic Holidays the 2 following parts are added:

8. Sacred Verses (after the 5th part) symbolized by Uranus.
9. The Song (after the 6th part) symbolized by Neptune.

In order to receive the full benefits of the Ceremony, people unable to be present may establish spiritual contact with the Priest or Guide; many persons are content to make the psychic union simply by reciting the Universal Prayer, which has been translated and distributed throughout all the countries of the world. This prayer, said every day at the same hour, truly creates a magnetic chain.

PEOPLE:

9) People are silent assimilating the whole Ceremony.

Silence. The people may leave quietly so as not to disturb the magnetic atmosphere.

In addition to the Cosmic Ceremony, the members of the Order of Aquarius also keep in contact through the practice of psycho-physical (yoga) exercises, which they do everyday for half an hour. A third spiritual connection is held everyday in each place for 30 or 45 minutes at the time of the Meditation in the Sanctuaries. Any Aquarian adept need not feel isolated when he can be spiritually united with all disciples in many different parts of the Earth:

SCHEDULE OF SESSIONS:	Argentina	Mexico	N.Y.	France	Central	Pales-	Tibet
<u>COSMIC CEREMONY</u>	Venezuela	Guatemala	Peru	Eng.	Eur.	tine Egypt	India
Universal Prayer	7AM	5AM	6AM	11AM	12PM	1PM	5PM
Initiatic Holidays	10AM	8AM	9AM	2PM	3PM	4PM	8PM
<u>YOGA</u>	12PM	10AM	11AM	4PM	5PM	6PM	10PM
<u>MANTRAS</u>							
Meditation	7PM	5PM	6PM	11PM	12AM	1AM	5AM

It is appropriate here to explain briefly the difference between meditation and concentration, so these states are not mistaken for idle imagination; sleepiness, or drowsiness where the student allows his mind to wander without control.

Meditation is a state where one's consciousness is directed one-pointedly to the theme chosen to meditate on, as well as everything that surrounds that specific theme. Let us take a pencil as a good example. As one begins to think on the pencil one notices that it is made of wood, one associates wood with the tree and from there to a forest, but if one is thinking suddenly on the bird chirping on one of the trees, the meditation has been broken. It is true that Meditation has a spiritual purpose, but the technique is the same. Meditation is like feeling oneself being periodically transferred to the theme chosen to meditate on, always with a well-defined direction. If one is not present in the Ceremony, one may nevertheless visualize it to the point that one perceives the incense, hears the music, or words of the Priest, and this means that one's thoughts are consciously directed to the Sanctuary. Those living in Aquarian Ashrams practice Meditation every evening. Only the INITIATES, or students who have received the authorization of a GURU (4th degree of REAL INITIATION) have the right to pronounce the mantras. All other disciples meditate around a Master or GURU who vocalizes the mantras while they themselves follow mentally the waves of sound produced by the psalms.

Concentration is a completely different thing altogether. In concentration one strives to "BE" one with the theme chosen to concentrate on. Following the example of the pencil taken before when one visualized the pencil and everything related to it, in concentration one attempts to be the pencil itself. Even though the example chosen might seem to be non-spiritual, please do not assume that yoghis are striving to become chairs, rocks or tables; it was chosen as a simple example and one may apply the same technique to more abstract or mystical themes. The technique of concentration

involves self-effacement of the thought which unites the mind and the theme. In meditation the personality remains and the practitioner is able "to see" himself and also to mentally visualize the theme of meditation. In concentration one cannot "see" oneself anymore because one is united, one with the object itself..(This is the end result of Yoga, the Dhyana experienced just before realizing Samadhi, the final stage of Re-integration into the Great All.)

Concentration is not an easy task, nevertheless, everyone is capable of practicing to attain a state of transpersonalization of the "I" and the object. With this in mind, the yoga students in the Ashrams practice the psycho-physical exercises (asanas, pranayama, etc.). It is of foremost importance to identify oneself to a GURU and even though one might not be capable of practicing Hatha Yoga perfectly, one's mental union with a true Yoghi, a Master, is of great help in the Yoga Path. In the practice of Concentration there is already an experience of relative identification where the practitioner forgets himself and becomes part of another up to the point of becoming all other things, that is, Universal.



## COSMOBIOLOGY NOTES

We need not make a defense of the Science of the Stars. Our writings are not intended to convert anyone and neophytes will not find easy subject matters in them.

Both astrologers and biologists have been interested in studying the Science of the planets. Herbert Spencer, the philosopher, stated that the science of human nature is not capable of establishing an absolute Law because it lacks the knowledge of all causes and circumstances which may determine the behaviour of individuals. On the other hand, he says, the Science of the Stars is capable of infallible predictions.

Descartes also agreed with the above idea and was surprised that in the midst of this creative Cosmos we are all taught symbolically the inexorable determinism as the Latin "Fatum" and the Greek "Ananke".

Bergson observes that the great Cartesian intuition is in agreement with the Aristotelic theory of local movement. Einstein declares: "You seem to think that the movement of a planet is in the center of two other movements. One movement tends to move constantly towards the Sun and the other tends to try to send it constantly on a straight line to the tangent, nevertheless you have never actually seen either of these two movements. It would be simpler and more truthful to say: the planet turns around." This is the Einstein notion of the curvature of space wherein a bright ray of light travelling indefinitely forward would finally return to its point of departure.

Our intellect finds itself most at home among material objects. It is fully satisfied when it is capable of understanding things following a cinematographic method, workable signs, fixed signs that relate to previous concepts, to the present day laws. In other words, the intellect needs to relate to things that can be measured in quantity and in harmony with the human science, in particular the modern one. A good example is the success of Astronomy through Kepler, Galileo, and Descartes which allowed the establishment of a constant relationship among variable magnitudes, that is, between variations of quantities of the phenomenon or of its basic parts.

There are, nevertheless, scientists who have rejected Astrology. Their main argument has been: "I have not been able to see anything, therefore everything else is fake." The candor of this argument is also full of pride because we all know very well that in order to see anything under a microscope one is required to study "microscopy"; just as in the case of an illness that one wishes to understand there is the need of studying symptomatology. Therefore, in order to practice Astrology one is required to study the heavenly spheres.

People are always asking the Astrologer: "Was I born under a good star?"<sup>5</sup> It is necessary to understand that no astrologer is able to answer with authority such a question. The date of birth of any given person will let the Astrologer know the sign of birth, but all that means is the passage of the Sun through that particular sign. For example, the fact of a person being born under the sign of the Ram (March 21-April 20) or the Bull (April 21-May 21) does not indicate particular characteristics, but rather a general tendency for all those born under that part of the Zodiac. Therefore, in order for an Astrologer to give an accurate opinion, he is required to consider many other factors. Each person enters the world under a very different sky. His appearance on Earth is known through the natal chart which in a way is a "cliche" or point of departure for the interpretations the Astrologer is to make. In this planetary kaleidoscope, no two natal charts are the same. The interpreter of the celestial vault cannot negate stellar influences and, at a certain moment, is capable of watching the configurations of the sky and predicting specific happenings. This is referred to as "interpreting a horoscope".

There are well-established laws and statistics which demonstrate artistic tendencies for those born under precise places in the Zodiac (the placement of the Sun during birth). People inclined towards painting are born at the beginning of the Crab, at the end of the Lion, at the beginning of the Virgin, Scales and Fishes. Research on the birthdates of 153 artists born between the 16th and 19th centuries give an average of births between the 5th and 10th degree of the Scales.

Statistics drawn on 2,800 birthdates of musicians show an average of happening between the signs of the Bull and the Fishes, specifically the 10th and 11th of May are the most favorable.

The beginning of the sign of the Lion is very favorable for producing actors. It is interesting to note that there is a decrease in birth rate everytime the Moon travels that part of the Zodiac. It is a fact that births happen by areas in the zodiacal wheel.

Studying the natal charts of numerous pianists, one finds the Moon accompanied by the planet Uranus and when both are 10 or 20° apart one may well predict a noticeable tendency towards musical criticism.

---

<sup>5</sup>The twelve signs of the Zodiac are: Ram, Bull, Twins, Crab, Lion, Virgin, Balance, Scorpion, Archer, Goat, Waterbearer and Fishes. These zodiacal portions are the symbolic path that the Sun travels on the ecliptic in one year through the twelve constellations as follows: Aries, Taurus, Gemini, Cancer, Leo, Virgo, Libra, Scorpio, Sagittarius, Capricorn, and Pisces.

Composers are frequently born under the sign of the Twins. Statistics establish general Laws: for example, a child with its Moon of birth in the sign of the Fishes has double probability of attaining old age, while another born with the Moon at the end of the sign of the Twins will have three times the possibility of becoming a great composer. An individual born the day when the Moon was in the second part of the Crab also has good chances for longevity.

Another question frequently asked of Astrologers is: "Which is the best moment to be born?" The answer is very complex. When the Sun is rising in a natal chart it denotes success; when the person is born between midday and midnight it denotes less success. Nonetheless, for someone born when the Sun ascends toward the East, there will be a number of difficulties but also several opportunities for success. Notwithstanding, the position of the Sun only provides very vague information.

The crescent Moon is preferred by some instead of the full or new Moon, but there are numerous other factors which hinder "good luck" in a person's life.

A person is born under a well-defined sky, and no other, and his natal chart has a definite similarity to the natal chart of his relatives.

#### BIRTH RHYTHM

Quetelet, the "Father of Social Statistics" stated that the greatest number of births happen between 12 midnight and 3 A.M. and the minimum between 12 midday and 3 P.M. Raniken, in Edinburgh, Burek in Hamburg, and Berlinski have confirmed such statistics, based solely on 1,000 cases each. According to the 86,850 births registered by Goelher, the maximum happens between midnight and 6 A.M. and the minimum coincides with the figure given by Quetelet. Astrology has demonstrated, according to 121,647 cases that the maximum circle between 12 and 2 P.M. and minimum between 12 and 2 P.M. is valid for both sexes, and this demonstration excludes any possible doubts.

#### ASTRAL INHERITANCE

One finds very often a coincidence in the birthdate of members of the same family. This coincidence happens both in the same month or even date of birth and cannot be attributed to pure chance. One discovers similarities also in the position of other planets, besides the position of the Sun. Research on 20,000 natal charts has proven inheritance as an astrological fact. For example, in a family of 18 members, the Dragon was found to be in close quarters to where it was positioned 30 or 40 years ago at the birth of an ancestor. Another case is that of a child born at 11:52 in Geneva, whose natal chart shows his Venus is in exact position to his mother's and the Moon, Mars and Uranus exactly on the ascendant, all of which confers

him the astronomical characteristics of his parents. An interesting factor here is that this birth took place after many hours of delay (counting from the beginning of labor) and was brought about surgically, that is, through an action sometimes considered "arbitrary" and controlled only by human will. The precision of how the Law of Astral heritage was fulfilled in this case, demonstrating there are no coincidences happening through human intervention, as in this case, in which the necessary timing was provided to accentuate the natural tendencies of astral heritage.

### PREDISPOSITIONS

Astral Heritage suggests that planetary positions such as angles and aspects, and complete natal charts correspond in their astronomical similarities to similarities in the physical and psychic aspects among relatives. An answer to this question is explained by saying that the birth Sign gives a general tendency toward a profession (for example, the Ram produces soldiers, the Bull, inventors, etc.) but specific predispositions are defined by well-defined factors. Statistics of 2,800 musicians show the Sun to be positioned at 19° and 20° of the Bull (this corresponds to the 10th and 11th of May). The latter degrees prove to be more favorable to musical predisposition than the 24° or 26° of the Bull or 9° of the Twins. The following areas have also been found favorable for musicians: the middle of the Bull, Twins, Crab and Fishes. Unfavorable for musical tendencies are: beginning of the Twins, the Crab and the Scorpion, and the end of the Bull.

The most favorable degrees for artists are between 5° and 10° of the Scales, while 10° of the Lion (in August) or the end of the Virgin (20th to 23rd of September) presents hardships to artistic development. The cosmos has specific times to give birth to those attracted to pictorial art. The most favorable times are the beginning of the Crab, beginning or end of the Scales, beginning of the Virgin or Fishes. Unfavorable for artists is the sign of the Bull (April 21st to May 20th) and the end of the Scorpion. In fact, as one studies the different categories of personalities, one may well say that composers are the most "lunatic".

According to traditional astrology the Sign of the Twins provides a fertile and very lively imagination, while the Sign of the Crab gives a serene and contemplative temperament.

Statistics represent general laws. For example, a child born at the time when the Moon crosses the sign of the Fishes would have twice the possibility of attaining an old age of 80 years old, than another child born when the Moon crosses the second half of the Twins. And on the other hand, the latter child would have three times more possibilities of becoming a successful composer than a child born with the Moon on the second half of the Crab which gives tendencies toward longevity.

It appears as if one is granted either success or longevity.

#### PROFESSIONAL VOCATION

Let us be reminded that the following continue to be general laws. The natal chart defines both the particular predisposition and the free will facing Destiny, due to evolutive aspirations. People born under the sign of the Ram are capable of choosing industrial professions ranging from laborers up to heads of industry, mechanics, adjusters, metallurgicians and everything that has to do with iron and metals.

The sign of the Bull is predisposed to commercial enterprises and industries, sometimes it also gives inventors attracted to the radio, and electricity in general. There are many politicians also born under this Sign.

The sign of the Twins produces designers, architects, and many times, people with great success.

The sign of the Crab produces notaries, clerks and secretaries.

The people who are constantly facing the general public are born under the sign of the Lion. These are organizers of events, initiators, and professors.

The sign of the Virgin produces scientists, serious researchers and religious people.

The sign of the Scales produces judges, administrators, commissioners as well as craftsmen, especially those working with wood.

The Scorpion produces labourers of art and surgeons.

The Archer produces great pilots and acrobats, Presidents of Societies, and women who direct schools or are administrators.

The Goat produces businessmen, bankers, and economists.

The Waterbearer produces very frequently great spokesmen, journalists, writers, and lawyers.

Great navigators are born under the sign of the Fishes, as well as people predisposed to medicine.

All the above paragraphs are limited for further explanations.

Many of our readers may be surprised to discover the importance of Astrology, nevertheless, it is important to note that everything is based on this important science, directly or indirectly. It is indispensable to study this science in order to understand all other sciences and to search one's own perfection without having to ask others for help. There has been much abuse and prostitution of Astrology from people trying to follow the advice of others.

The Scripture says: "Days shall come when all that is occult shall be revealed..." and this is nothing but the universal knowledge of Astrology. Each person will acquire the knowledge on how to erect a natal chart and interpret this heavenly map, just as nowadays people know how to read and write, although the latter was once considered to be a special privilege for the learned few.

There will always be proud individuals who cannot admit that others know more than them. Why aren't they surprised to see how musicians produce music while others who have the most exquisite instruments are not able to play one musical note on them?

Many serious individuals easily support Astronomy and Astrobiology which has recently been praised so much, nevertheless they are unable to accept a prophecy. These people are on the side of experimental Astrology and become enemies of deductive Astrology which, by the way, is much more interesting.

What people are really lacking are the philosophical facts which will allow them to understand what intuition is all about.

The word intuition, as well as any other words of human language, has the inconvenience of limiting and deforming the reality it wishes to represent. Therefore, in order to bring up a new concept, one needs to strictly define its meaning and limit its use and even then the word itself will reflect the meanings the word had before and people will bend to the false use of their intellect and very soon the interpretation of the word will be brought back to its most common usage. It is true that most individuals think through ideas "already made beforehand" rather than through ideas studied by them.

Bergson needed to find a word to describe a specific effort of the intellect and from then on his doctrine has been referred to as a Bergsonian "intuition". Since then, such "intuition" has been admired or criticized, without really understanding deeply what Bergson was describing with that word.

The meaning of a word is usually defined by the use one gives to it, similarly to the way a method manifests itself in the applications of it rather than through the definitions made of it. It is against all the rules of logic and reason to judge an intuitive method without having studied its applications.

Intuition is mostly defined as a mystical, irrational, and maybe even anti-rational process which escapes any type of control. The faculty of intuition is limited to the word which represents it and is given its most common meaning. Intuition is easily understood as an instinctive guess, a vague presentiment, without a well-defined reason. These interpretations are very far from the mind of a true student. I do encourage us to take into consideration the work of Bergson and to understand that one cannot demand a philosopher to know all

sciences, nor to deeply understand one of them even if he specializes in it. At present, the use of time is similar to the squaring of the circle. Nevertheless, the philosopher needs to be capable of assimilating those sciences which will be necessary for his own studies and to continue to be up to date in their development. This is almost impossible as Bergson was able to prove, because this philosopher proved to be more scientific in his philosophy than most wisemen. Intuition does not stop intellectual work by any means, rather, it comes as a by-product, it perfects and crowns it. It is expressed through the one who knows in a qualitative order. The diagnosis of a doctor, for example, is an intuition he has obtained in a slow and constant manner and this proves that intuition does not always precede analytical thought nor does it stop discursive reflection. Intuition is already present in its natural state in all our thoughts and we need to prepare for its expression through a slow and serious analysis and studying every facet of it.

The precise and scientific knowledge of facts is the first condition to further metaphysical intuition which penetrates the principle itself.

Intuition will not be understood anymore as a "hunch" but rather as a spontaneous sensation, by the immediate understanding of the fact as a result of our previous research, as the by-product of the interpretation of our knowledge.

Randomness does not belong here, due to the fact that a hypothesis cannot harmonize with the law which states that there are no effects without causes, nor causes without effects.

At present Astrology has been recognized as an official Science and many institutions, organizations and administrations make use of it.<sup>6</sup> We are beginning to see astrology used to find answers to most of our modern problems. Naturally the area of "prediction" is the most delicate of this Science and one needs to be careful not to demand too

---

<sup>6</sup>As any other corporation, the astrologers have a Union and the author is President of the Worldwide Society of Cosmobiology and the Federation of Scientific Societies where astrology occupies a very important area. The government incorporated the Federation and it now has an official credential. Many times the author collaborated with the national newspapers and radio who requested his services to offer an astrological answer to vital issues.

much precision<sup>7</sup> from an interpreter of the sky who is human and bound to make mistakes as any other, especially when most of the people who provide him with information do so erroneously. It is very important to have the accurate information regarding the exact date of birth, the place, and the hour.

---

<sup>7</sup>Many clients go to an Astrologer to ask the color of eyes and hair of the person they are supposed to meet in the near future. Others are interested to know the winning number of the lottery!



## THE GREAT ARCANES

During our evening philosophical discussions we often study the great symbols of this world or commentaries on Sacred Texts, and truthfully both of them belong to one same teaching: INITIATION.

Let us take an example of one of our evening studies when we studied a symbol known by occultists as the symbol of the Great Arcane (see Figure).

It consists of a big circle which represents the traditional magical protection, and also known as the secret knowledge of the Ecclesiastical Crown. The cross representing the elements appears twice (as above, also below), and the horizon is also represented: the macrocosm and the microcosm. The dark area represents the material universe where we dwell until we can attain the Throne of Justice, a degree attained by the adept once he is capable of escaping daily influences. There are also two lines crossing each other and forming an X, the St. Andrew Cross, the letter Khī, first letter for the words Kone, Krusos and Kronos, the gold, the crucible and time; the great mystery of the Great Hermetic Work. The St. Andrew Cross is a hieroglyph which represents luminous radiations originating from one and only one center. The two snakes represent the active and the passive, the solve and the coagula, the expansion and contraction, the Ida-Pingala, the analysis and intuition, the two great principles of the great Lights, the powers of the Day and Night. The sword is the staff mentioned in the Bible in Exodus and it represents Kundalini, and along which we can see represented the CHAKRAS (plexus or nerve-fluidic centers). The cusps on the big circle represent the four royal stars: Aldebaran (The Eye of Taurus), Regulus (The Heart of Leo), Antares (The Heart of Scorpio), and Fomathaut (The Mouth of the Austral Fish), as well as the four directions: Ascendant, Nadir, Western Angle, and Zenith.

The mechanism of the G.A.:. is very esoteric, to the extent that some lodges that display it as their emblem only know a very simple interpretation of it. Our Order comes to reveal all mysteries, nevertheless, I cannot reveal in this book the entire mystery, for reasons well known by Initiates and simply because the novice would not even be able to understand certain explanations which need previous research. Sometimes too much light can be dangerous.

If we were to continue explaining all the esoteric meaning of the Great Arcane we would have to follow the information given in specific Chapters of Exodus, Nehemias and Daniel in the Bible.

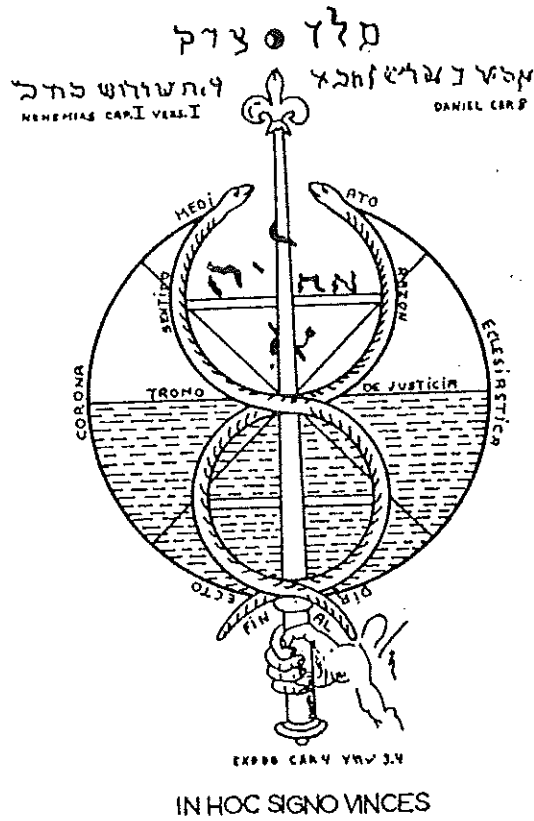

One of the esoteric emblems which, in the same manner of Tibetan mandalas, Egyptian and Mayan graphics, Assyrian paintings or Templar inscriptions, is studied by the Initiatic Schools of the Universal Great Brotherhood.

The center or plexus No.1 is symbolized by the hand holding the handle of the sword and it represents the state of Matter when one awakens to the need of being transformed. In other words, it is the stage of "the adept" but it is not considered as an initiatic degree (8). Transmutation is well explained in the Bible in Chapter 4 of Exodus. The penis is represented here by the sword which also symbolizes the Nadis (9) in charge of illuminating Kundalini.

Once the adept has understood the parable of the transmutation of the snake (symbolized by the hand holding the penis) he elevates himself above matter but this does not win him any degree. It is mostly a preparatory stage for the first initiatic degree which requires the basic studies on Astrology and Yoga (10).

Aided by the aforementioned studies and having glimpsed the first mystery, the adept continues on the road of perfection and has to reach the second step, the custody of the sword, where the two tails of the snake cross each other. The word "Direct" in the figure gives a clue to the true nature of this degree. The disciple is now clearly linked to all things, and will understand the importance of religion and magic. Finally, he comes to understand the first path which he needs to travel.

Once the candidate reaches the third degree, which corresponds to the Solar Plexus, he acquires power over the elements and can rule certain circumstances, while one Initiate on the fourth is capable of control over them. The center line (the Throne of Justice) controls the Zodiac. The dark half of the drawing represents the fact that the candidate has elevated himself but still remains on a terrestrial plane on the visible domain. Later on he shall escape habitual influences completely to penetrate superior layers through two vehicles: the intuition and reason. Once he makes contact with heavenly harmony this proves that the Initiate has become a true Master. He unites with the Cosmic forces, with the Universe and celebrates a completion with all the elements.

---

(8) We refer here to several expressions of Mastership called initiatic degrees. These correspond to a process guided by a Superior Direction rather than the distribution of degrees granted easily by sects and occult societies.

(9) The top of the Nadis is the power of HOMKARA, the form of AUM, the spinal chord (SUSHUMNA) that reaches the brain and functions thanks to its 72,000 channels (the nadis). This current branches out and penetrates the whole body.

(10) The study of the sciences would not refer only to horoscopy but rather to esoteric, religious, and evolutionary astrology. Regrading Yoga, it is not intended for one to study an eastern philosophy, but rather to become a complete Yoghi, at least one hour a day by following a strict and serious discipline.

Before attaining the fifth degree (cross-road on the Higher Cross) the Hebrew letter Aleph represents the Man who is a Son of God (one could also draw here a five-pointed star). The famous axiom: TO KNOW, TO WILL, TO DARE, TO KEEP SILENT corresponds to each one of the first four chakras.

After the disciple penetrates the Ecclesiastic Crown, he knows, and he has realized the sacred plexus, ruled by Saturn, the planet identified with KNOWLEDGE. He who reached the third step, or solar plexus, is one who has persevered, who has made use of a high concentration of his energies, thus acting out the words TO WILL. The awakening of this chakra develops the will power. In the fourth degree, one finds the cardiac plexus and the adept is required TO DARE to leave terrestrial spheres, or the so-called human plane. TO DARE corresponds to the sign of the Lion and those who study astrology know the intimate relationship of this sign with the cardiac plexus. The centre of the higher cross in the figure (the fifth degree) corresponds to the last word of the axiom and identifies with the Sign of the Scorpion. It is the site of the pharyngeal plexus and according to astro-biology it corresponds to the thyroid gland. Mercury is the ruler and controls speech and interestingly enough, the candidate learns how to apply the words TO KEEP SILENT.

The areas of the body we have just mentioned in the last paragraph should not be taken as exact areas, but we have chosen them to clarify, through words, the subject matter we are studying. Nevertheless, these explanations are a poor description of the Great Knowledge. The numbers are relatively describing degrees for lay people and rightly represent different expressions which are well-understood by Initiates.

In order to fully realize the esoteric sense of the Scorpion (represented in occultism by an Eagle) the Initiate crosses a zone in constant transformation, marked on our figure by an intended deviation of traditional IEVE (11). This is the sixth degree (the exit from the Zodiac) referred to in Hinduism as the opening of Brahma. It refers to the complete enlightenment through the two great paths, the meditative and the reasoning. Aided by both contemplation and Science, the Master is elevated to the higher degree of human potential. He has also been in touch previously with the etheric spheres and usually his physical body shows special marks and his face expresses the state to which he now belongs.

---

(11) This transformation is referred to as the Work of the Divine Name. The knowledge of men expresses the understanding of the Name of God (rather than of conventional interpretation to the letter) in an algebraic equation thus:  $ax^2 + bx + q = 0$ . (a and b are applied to the "iod", the 0 to "vau" and the x corresponds to "he" both in the first and the second).

He still lacks certain conditions to go up higher, but those belong no more to this world. These higher manifestations are described symbolically in the secret lotus (house without base, radiant flame, etc). In the Great Arcane, the fleur de lis symbolizes this sublime degree of three unities, which is the maximum expression before attaining the divine substratum. That is the seventh superior center, the degree which corresponds to Masters and Great Instructors of Humanity in Secret Initiation. It belongs to the Patriarchs and Messengers of Christic and Buddhist Planes, the Divine Incarnations: Avatars, Oints, Boddhisatvas, Messengers, etc.

The aforementioned are just superficial explanations of this symbol which is complex and of which we cannot reveal the secret totally.

During the classes in the Initiatic School, one studies more esotericism, according to the degree of the students attending, because Initiation is gradual and each one receives what he is ready to receive. Many teachings are only given from lip to ear, that is directly from Master to Disciple.

We wish to present some of the courses given in our centers, and which refer to a variety of teachings in order for the reader to realize he can find the path that suits him and at the same time assimilate other studies. The aforementioned courses are only given to people with a good philosophical and spiritual background. One needs to be able to understand words and ideas clearly. On the other hand, for those adepts who already arrive with profound knowledge, the Master has a more advanced and special teaching.

The four following brief articles are studied at length in our Initiatic Schools. Therein, we study the esoteric meaning of the symbols at depth and also the relationship of symbolism to the universal and divine Laws.

The international press has published them in the form presented here. My purpose has been to provide people with food for thought to realize that there are many things that life offers in addition to ordinary happenings. Our ordinary lifestyle has surrounded us with a specific level of experiences to which we become accustomed and we forget to penetrate the luminous dimensions of superior possibilities. We overlook new horizons, wherein one can find ways of behaviour which are truly elevated. One needs to be reminded how to visualize correctly the symbolism inherent everywhere and in everything. One needs to get in touch once more with the tradition which, since time immemorial, reveals to both the educated as well as the laity the "keys" of the set of laws which rule the human being and the infinite universe. These laws have been deformed in several instances but nevertheless still maintain their original motivation intact and it is possible to use them to develop a completely new civilization for our times as well as use them for individual needs.

An ordinary lifestyle lacks the acknowledgement of a higher expression of existence and the sublime methods of transmutation, both up and down. The prime objective of our studies is, then, the expansion of consciousness.

## MAGIC IN THE XX CENTURY

Treatises on magic are nothing new. We wish to present here concrete data, serious explanations of facts presented by official science and proofs given by wise doctors.

Through secret doctrines we enter an esoteric domain but opposing these grand theories is the horrendous skepticism of the mechanistic-materialistic mass. One cannot stop to recognize that we are surrounded by mysterious powers of which we can hardly give a purely physical explanation. We need to be courageous to declare our impotence, moreover, our weakness, when we face the Great All.

If we could go back to study all the works which were destroyed during all ancient wars, we would be able to have a wonderful source of information. Very important teachings were lost every time a great library was destroyed! Alexandria's library was one of them (12). Here and there one can still find something, such as the collection of Egyptian papires in Leide, Holland which belong to the Third Century. There are 75 and were seemingly used daily in Magical ceremonies to produce a thaumaturgical effect through mystical love.

Although there have been writings kept from ancient times, the only true vehicle for the transmission of teachings has been oral. All other "keys", "prayers", and "parchments" remain as points of reference for Initiatic life. In all sects one finds rites, manuals of dogmas with charts, seals and formulas to represent similarities, but always the Masters are there to Initiate the Adepts.

Even the country sorcerer always is ready at his time of death to "transmit his power".

---

12 700,000 volumes from the Library of Alexandria disappeared during the time of Caesar. A new collection was again destroyed under the rulership of OMAR. The vandalization of ALESIA destroyed all the teachings of the Druidic Schools, estimated to be 200,000 volumes. Byzantine was burned by the Iconoclastes. Thirty libraries were destroyed during the invasion of Rome by ALARICO. During the Middle Ages, all the books on occultism were used to light fires.

## A MAGICAL CENTER: THE DRUID STONES

In order to obtain Initiation, that is to say, the title of a Druid in olden times, one had to demonstrate one's capacities through study and merit. Geographers, poets, historians, and philosophers have given much information regarding the organization of the Druids. (13)

According to the Gaelic, there were several forms of worship. Nowadays one finds the same thing in religions which have an exoteric part, or dogmas which they teach to the masses, and an esoteric part reserved only for Initiates. This is why many times the demi-gods of popular worship were mistaken for the worship of Divine Spirit, reserved only for the few Initiates (True Druids) who could not accept that God in his Infinite Greatness was represented by images or enclosed in 4 walls. For the Druids, Nature itself was a Sanctuary. The dolmens are uncut rocks, that is, not touched by human hand. The oak was the sacred tree for the Druids. Also sacred for them was the mistletoe, considered as their emblem. The Druid centers have often been mistaken for old cemeteries, but truthfully these are circular formations for specific magical centers.

The worship to the ancestors was followed by the Celts (referred to as GALLI by the Romans and then GAULOIS, that is, the first French) and one still finds the megalithic monuments (which means great rock in Greek) of Carnac. (There were more than 15,000 monoliths before the 16th Century. After that time they were used for buildings and nowadays only 2,000 of them remain.) One also finds the line of menhires which begins in Locmariaquer and ends up in Erdeven, totalling 145 stones at the furthermost corner of Scotland (Shetland and Orcaide Islands). There are 144 stones in Stonehenge in Cambie, and 67 stones in Donegal, Ireland. All the latter were built by peoples who believed it was propitious to bury their dead close to the Ocean to help them lift up their souls.

Strangely enough, spiritists believe these stones to be "speaking tables".

Mostly the power of the Druids was based on magnetism and hypnotism. That is why Plinius referred to them as Magicians.

The radius of action of higher psychism may extend to the farthest end of the Cosmos. Sometimes, one cannot attest to it through the physical senses; nevertheless there is a quotation from the Secret Doctrine which says: "Interstellar space contains celestial spheres in the ethers which are invisible to us." Even

---

<sup>13</sup>The Druid priesthood comprised 5 degrees: Bretons, and Gales, Drotts, Ases Varaighes and Slavs. Similar to the 5 degrees of the Egyptians, these correspond to the 5 Divine Faculties, and to the 5 Sacred books. Here is a chart of the Dactile Key:

$$5, E = \frac{10, Y}{2, B} \quad (\text{according to St. Yves de Alveydre}).$$



if one is not familiar with the plurality of worlds, it is useful to conceive of the Cosmos as inhabited by beings who live in psychic bodies unimaginable for us. The power of the Magician is based in assimilating these particles and then he can use this power for good or for evil.

With the appearance of theories of the vibrational waves and electromagnetic phenomena, we nowadays have a vague idea of the fluids that surround us. On the other hand everyone is presently aware of the influence of music, words, colors, perfumes, and food on the psyche, as a result of the correspondences of the ethers in the transformation of the physical energies into psychic energies.

In the outskirts of Paris, there is a place visited by the general public for entertainment, which is truly a strategic center of Magic. It has a circular form and has a special position for the elements. It is oriented in the right manner; therefore, all these are proofs of its authenticity. The builders of churches also chose the appropriate place, in most cases selecting ancient temples already dedicated to some divinity wherein there is a certain amount of magnetism. (Our Lady of Paris is built over an ancient Templar sanctuary which had been a magnetic center since time immemorial. The Cathedral in Mexico City was built over an Aztec temple which was also an Initiatic Sanctuary of the Calmecac School.) The stones in the Meudon Forest near Paris are witnesses to the ceremonies that were practiced there many hundreds of years ago.

There is an oak tree around which several menhires and dolmens are located in perfect order, and which is clearly understood by Cabalists. The view and environment do not correspond at all to a place near a city. At a distance of a "dreve" and in the midst of a grove there are a group of stones which very well remind one of pre-historic times.

There is a stone in the center of the grove which still has black prints from fire, having been used together with a silex, and such stone is the altar. To the North one finds the menhir which represents the table and following a circle towards the East, all the stones diminish in size gradually. A basic dolmen complements the next one, and both together become the stone of command, exactly facing the great Oak. To the South one finds two dolmens which provide balance and are much smaller than the others. Finally on the West, one finds the vegetable entity in charge of receiving shocks (the Oak also symbolizes the "triangle of apparitions", well known to Magicians). The oak tree is united with the menhir through a line of very small stones and is also surrounded by half a circle formed by pebbles towards the center of the large circle.

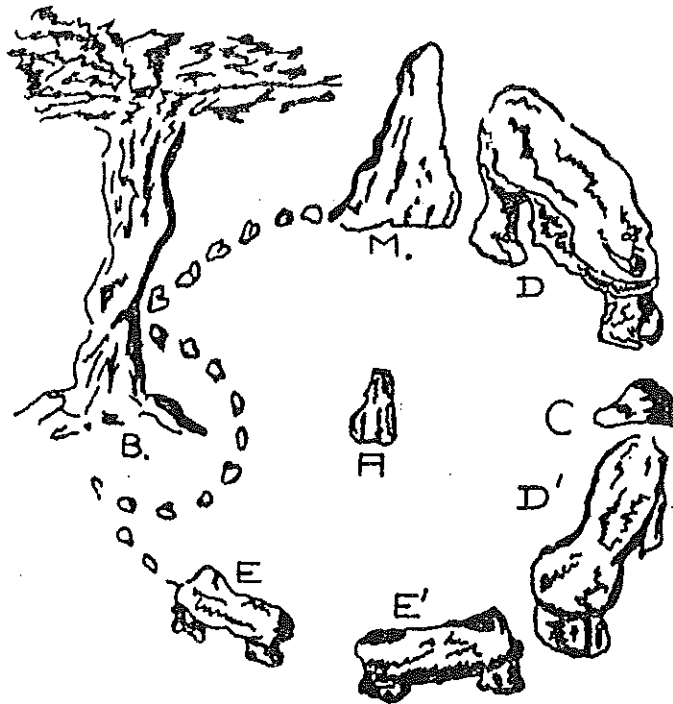

Study of the elements of a magic center of the Druids in Paris

- A - Central stone.
- B - Oak tree (vegetable entity).
- C - Stone of command.
- D, D' - Basic dolmens
- E, E' - Stones of balance
- M - Menhir

In addition to their Ceremonies, the Druids lived in a very special environment.

The arrangement of stones in the Meudon Forest has many symbols. The lunar image is seen clearly in its first phase waxing, which is the power in action.

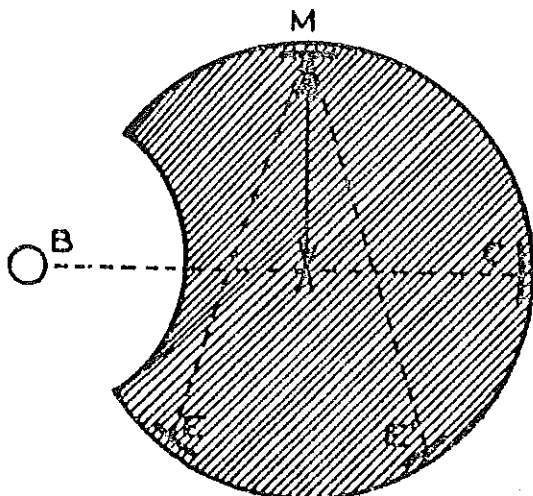

The axis C - B from the stone of command to the Oak Tree denotes the separation of the two worlds. The power of the menhir is increased ten times by the force of projection given by its perpendicular, A, to the axis B - C (cardinal points; west-east) and resting its two antennae on E, and E', which are the stones of balance.

## Symbolism

The star formed by these main elements is typically the microscopic paradigm which describes the action of Man in the macrocosm.

This pentacle is very important during the theurgical ceremony. It is important to notice here that the pentagram is not inverted, representing passivity, but rather it is pointing upwards (to the North). This represents Man acting on matter. It also symbolizes action similar to the sign of union of the Pythagoreans, which was a man with open arms in the form of a cross. The inverted pentagram has two points downwards and represents the "head of a goat", the principle of negation.

The stone of command corresponds to Jupiter, the Great Lord of Heavens, he who trains Leaders. The Oak is symbolized by Venus who produces union between the worlds. (This star corresponds to the Greek Aphrodite.) The Sun, materialized in the menhir is the point of departure of the system. Mars (Eso of the Gaelic) creates division, and is the stone of ara, the "D" dolmen (first basic stone). Saturn, sensitive to malefic energy is the second basic dolmen "D". Both form the couple of sanctification. The two balancing stones E and E' are represented by Mercury, the intellect and by the Moon, intuition, as well as by reasoning and impulsiveness to create balance on the table of the menhir.

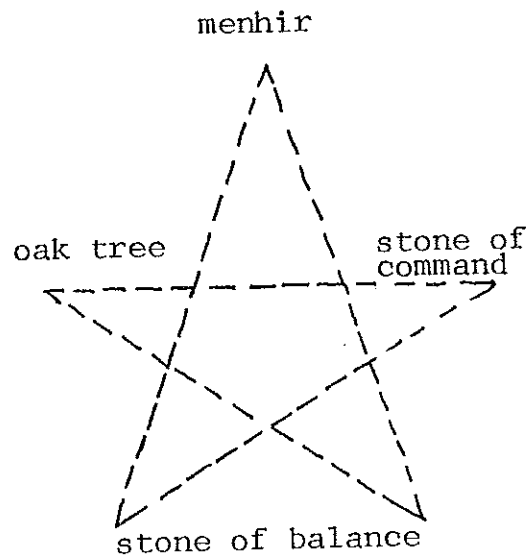

In a perfect order and following their natural evolution, the planets form a seven-point star. The point of departure is the Sun, ruling Sunday and follows up to the Moon, ruling Monday, then Mars, ruling Tuesday, Mercury, ruling Wednesday, Jupiter, ruling Thursday, Venus, ruling Friday, Saturn ruling Saturday, and then coming back to the Sun to complete the Star of the Magician.

Man acts upon matter in seven different modes. The seven elements in the Meudon Forest correspond to those seven modes. Both in religious and hermetic philosophies one finds the number seven as an important symbol. The septenary is found in the seven days of the week, the seven musical notes, the seven colors of the spectrum, the seven stages of matter, the seven cardinal sins, the seven evolutionary chains, the seven humanities, the seven Kingdoms of Nature, the seven different ethers, the seven physical senses to be developed. There are also moon phases in multiples of seven, the renewal of the tissue cells happens in

seven years, and is recognized by modern science. The brain of the child is also formed in seven years.

The manifestation of the Worlds also happens in seven planes: DIVINE, MONADIC, SPIRITUAL, AFFECTIVE, MENTAL, ASTRAL and PHYSICAL. The "Mens agit at molem" (the spirit moves matter) in seven modes: Solar, Lunar, Mercurial, Venusian, Martian, Jupiterian, and Saturnian. All the latter is well represented by the planetary correspondences of the seven pointed star formed by the megalithic monuments found in the outskirts of Paris.

One cannot regard the latter as a coincidence, in the same manner as one cannot accept there is a coincidence in the way a radio set is put together. Several years ago it would have been regarded as magic by some.

Aren't our modern physicists the sorcerers of the past? Perhaps the names have changed but one need not feel disgust for old words: Alchemy disappeared and isn't sorcery a way of hyper-chemistry nowadays? Wherever physics ends, magic begins.

There is absolutely nothing supernatural. There are supra-normal phenomena such as fluids, vibrations, and rays which cannot be denied as it was customary two or three centuries ago.

We are at the dawn of a New Age where ancient knowledge comes to the foreground again. May open-minded individuals collaborate with serious researchers in order to conquer once more the spiritual riches of antiquity.

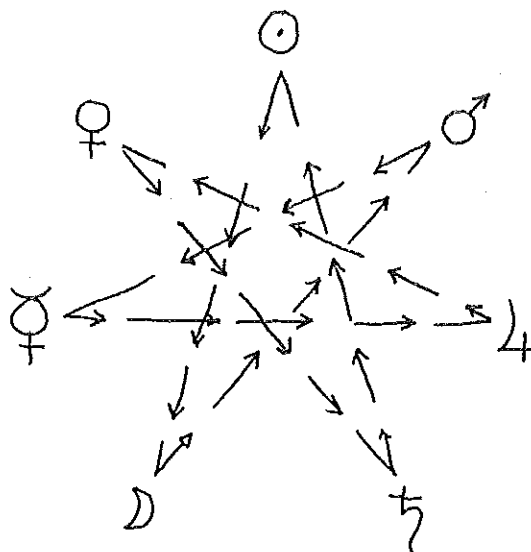

## THE ATOMIC AGE AS SEEN BY ASTROLOGY

Nihil Novi sub Sole.  
(There is nothing new under the Sun.)

Since time immemorial, Man has gazed at the heavenly vault, where hundreds of thousands of stars challenged him. (At present we know there are hundreds of millions of them, of which approximately 6,000 are visible to the naked eye.

One is astonished and humbled upon discovering the many parallelisms which explain to us the homogeneity of the Great All: The Macrocosm and the Microcosm are intimately linked.

Dr. Lavezzeri has noted the intimate relationship between Astronomy and human life. The 72 heartbeats of the human being correspond to the 72 years that the Sun takes to retrograde one degree through the heavens. The heart beats 4 times while we take one breath. That means that we breathe 18 times per minute and this corresponds to the 4 seasons and the 18 years of mutation of the terrestrial axis under the influence of the moon.

The 25,920 breaths for every 24 hours correspond to the great cycle travelled by the constellations to complete a zodiacal round through the precession of the equinoxes. 25,920 years divided by 12 signs are equal to the 2,160 years that it takes for the Sun to travel through each sign.

The period between 4,320 and 2,160 before our present age corresponded to the sign of the Bull which symbolized Egypt and Chaldea, and was represented by religions in their emblems in Crete, Assyria, etc.

Next came the Age of Aries which transformed religion. Moses forbade the Hebrew people from the worship of the Golden Calf and thereby diminished the adepts of the Apis Calf. The Christic Age began when the Sun entered the 21st of March of Year one in the following sign of Pisces, which brought about a transformation of concepts. The first Christians identified themselves by drawing a fish and Jesus referred to this emblem frequently.

Naturally, the changes in symbolism do not happen abruptly, and the great precessional cycles have defined the history of the peoples. It is well known that the end of Winter merges with the beginning of the Spring and that Summer lasts into the Fall. The change of seasons is not abrupt and renewal comes about "en crescendo". All great civilizations have been defined by this precessional movement.

We are at the dawn of a Golden Age. The Age of Aquarius which is just beginning marks a new cycle for a rebirth of well-being, a period of peace, a wonderful realization of Brotherhood.

There are many people who correlate this New Age with the discovery of atomic energy. Observers of the Heavens like to mention Uranus which in astrological tradition symbolizes violent happenings and is the ruler of the constellation of Aquarius.

Many individuals have been scared by destructive possibilities and ask themselves if it is possible that the atomic discoveries may affect the astral influence. We can definitely answer with a NO. That discovery was already taken into account in the luminous poem that men were unable to discover.

In the aforementioned poem Mercury represents intelligence and symbolizes science and Uranus represents abrupt happenings and an unleashed power. The union of these 2 planets in the sign of the Twins in June 1945 had to coincide with the tapping of the secret of atomic energy, although very few men were able to read this sign in the Heavens. In traditional interpretation, the conjunction Mercury-Uranus denotes intellectual activity and is beneficial for new and daring actions. Therefore, that was a transcendental conjunction for our Century because Mercury was in the Twins (its own residence) with Uranus, which was positioned in its own environment in a sign which denotes evolutionary cycles under the rulership of the element Air.

It is important to realize that we did not at all "invent" the atom. We will never know how well the ancient peoples understood these types of transformations.

Berthelot stated: "Rational concepts attempt to know and attain everything. It strives to give a positive and logical explanation to everything and even reaches out its fatal determinism to the moral issues..."

Berthelot, a famous wiseman studied Alchemy a great deal and discovered a great number of substances similar to the metals and mentioned also several precious stones from Egypt (such as the CHENEM, a ruby, red stone or red glass; NESEM, a clear whitish substance; TEHEM, topaze yellow jasper, an azure enamel or yellow glass; HERTES, milky quartz, white, stucco, white enamel and other bodies which are equivalent to the "Titans" (a Greek word meaning salt). Nevertheless, the substances which nowadays we would classify next to the mafek and the chisbet were not mentioned at all in Egypt. Apparently, ancients had a more diversified concept than ours in this regard. The analogies which have preceded the structuring of our present day classifications are difficult to locate, although the use of signs and words has always existed in chemistry. For example, a few centuries from now people will see the generic word "ether" used without distinction to designate different bodies such as ordinary ether, whale's fat, oils, nitro-glycerine, cotton-gunpowder, sugar cane, etc. and not having studied the theories which enclose different bodies under the same definition of a common function, they will be perplexed...

In regards to the correspondence between planets and metals, these can be fully expounded in the commentary of Proclus on the Thimeus, as follows: "Natural gold, (this seems to mean he knew there was an artificial gold), silver, and each one of the metals, as well as any other substance, are all originated in the earth under the influence of heavenly deities and their effluvia. The Sun produces gold, the Moon, silver, Mars, iron, Saturn, lead, etc.

If we could get our hands on ancient documents of past civilizations, maybe we would find cryptographic writings with the theories of which nowadays we believe ourselves to be the inventors.

Be it as it may, the atom of our Solar System; in the infinitely small, has a central nucleus (the Sun) and its electrons (the Planets), satellites which are always circling around the proton and remains within the frame of the unity of Matter (symbolized by the Uroborous, a snake biting its own tail). There is an eternal similarity in everything and it is inevitable to start again and again. Everything is ONE and THERE IS NOTHING NEW UNDER THE SUN.

It would be arrogant for Man to believe that he has the power to stop time. The arrogance of the human being seems to have no limit but his free-will is fortunately predetermined and the Great Direction can only come from above. Throughout time immemorial a great book has been revealed to us: the heavenly vault. Only Astrology can guide us therein and reveal to us part of the Great Mysteries.

#### THE MYSTERIES OF SOLOMON'S SEAL

The Star of David is formed by two interlaced equilateral triangles which represent the two worlds: MACROCOSM and MICROCOSM ruled by the Ternary. This is a neutral way for the expression of knowledge.

The Secret Science teaches us that the numbers found at the angles of such a Star contain a great deal of information on occult subjects. Combining these numbers one finds historical dates of the Jewish religion or of special significance in the history of the children of Israel.

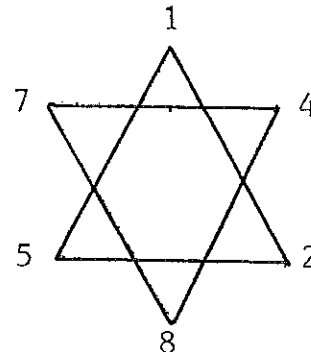

The Magical Number in its normal order: is 142857 and studying the first number on the highest angle the hermetic meaning is as follows:

- 1: Universal Principle
- 4: The Elements ( Fire, Air, Water, and Earth). manifesting the Universal Principle.
- 2: The number of division. The opposite elements: the Water opposing Fire.
- 8: Multiplication by division of cells (2 x 4). Matter, which originates Being.
- 5: The number of Man, represented by the Star of 5 points
- 7: The sickle, symbol of Death.

When one multiplies this number (142857) by 2, 3, 4, 5, 6 one finds amounts with similar numbers and always positioned in the same perfect order.

142857 multiplied by 2 = 285714

142857 multiplied by 3 = 428571

142857 multiplied by 4 = 571428

142857 multiplied by 5 = 714285

142857 multiplied by 6 = 857142

There is an exception when one multiplies by 7 (the number of Death). 142857 multiplied by 7 = 99999. 9 is the number of the Seed, of planting, of rebirth which requires 9 months.

#### PLANETARY CORRESPONDENCE

Everything in Life is related, the musical notes, colors, planets, etc. It is therefore important to study the stars which correspond to the numbers inscribed in the Solomon's Seal.

1. (At the top of the Star). Represents the Moon. Asthaite or Astaroth, the Goddess par excellence of the Heavens for the Semitic people. Isis for Egyptians. Ischvari for East Indians. Ishtar for the Assyrian-Babylonian. Juno for Carthaginians.
4. Corresponds to Mercury, the God of Eloquence who is also Hermes in Greek. He should not be confused with the Egyptian THOT.
2. Symbolized by Mars, the soldier star who creates division (Eso for the Gaellic).



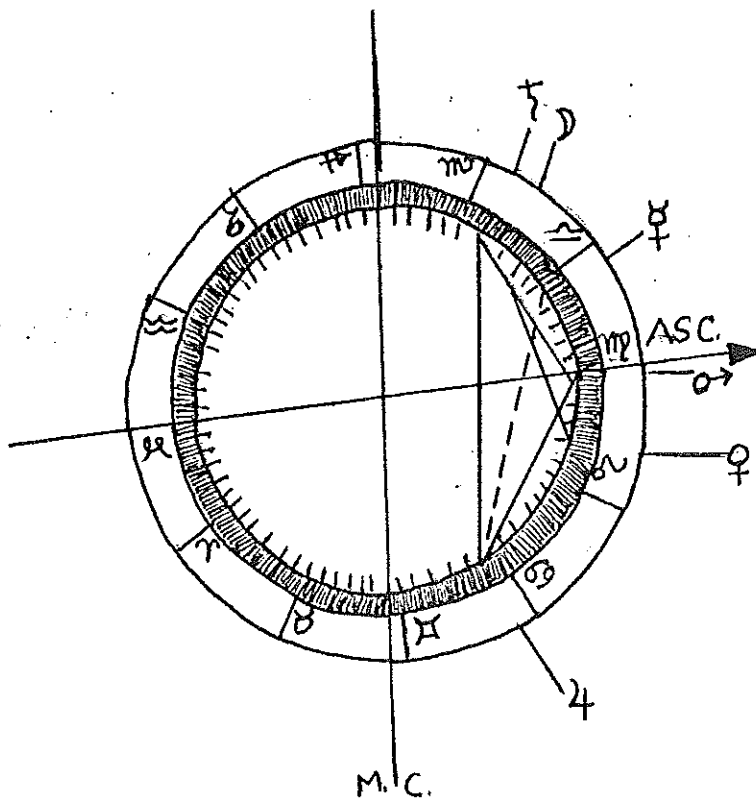
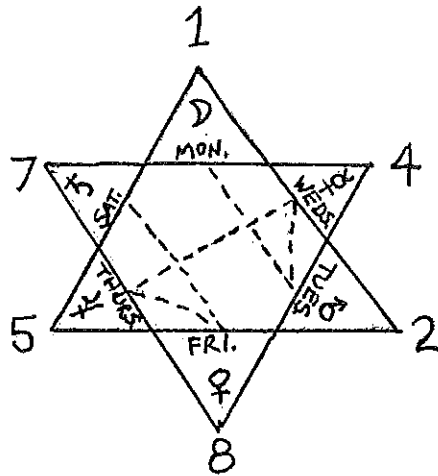

Important Signal prophecied in the Sacred Texts of a Heavenly Chart: the Solomon's Seal in Heavens as observed at the beginning of the year 5714 of the Hebrew Calendar (8 to 12 of September of 1953).

8. Venus. Aphrodite for the Greeks.
5. Jupiter. Zeus of Greek mythology. BAAL for Phoenicians, BEL for Babylonians. TAO in Chinese. PALA in Sanskrit.
7. Saturn. Subject to negativity.

The absence of the Sun in this planetary grouping is understood by Initiates and it refers to the Occult Power.

This grouping also explains the platonic dome, as one follows the planetary symbols through the days of the week. The drawing in the center of the figure is related to number 33 of the talismanic symbol of Agrippa. This number also symbolizes the death of Jesus at 33 years of age. Moreover, these numbers when studied in the light of the KEYS OF THE CABALA provide wonderful explanations. This text would not be the appropriate place to analyze this esoteric study in depth.

The chart of the heavens for Sept. 12, 1953 is quite interesting and marks the beginning of the year 5714 of the Judaic age and one knows it has not been chosen haphazardly because it is a multiple of the magic number....142857 times 4 = 571428.

First coincidence: at the beginning of that year the position of the planets is identical to the planetary location of Solomon's Seal. (Compare the planets' order in the figures).

Upon casting the Horoscope one finds a sign for a new Judaic Age. Within the framework of a simple and traditional astrological interpretation, the horoscope provides many aspects which denote not only evolution but a total transformation of Principles. We cannot offer specifics here but we shall use the word Rebirth, a moment of departure for a new stage in the life of the people of Israel.

In brief, important happenings are awaiting the descendants of Solomon. The astrological aspects prophecy the formation of a Judaic state with the arrival to power of an energetic leader, in a certain way the messiah which the children of Israel have been waiting for so long, but in this instance presenting himself in a more human plane in accordance with our present day materialistic society.

On March 15, 1947, an article of mine appeared in the newspaper Previsions in Paris expounding on the above mentioned issue of the arrival of a Jewish King and the formation of a State of Israel. All this is quite interesting, especially because Palestine seems to be in the news often nowadays.

I was not at all surprised, therefore, when I read last July in the French news an article which mentioned the "restoration of the Monarchy in Palestine", under the title, "The crown of the King of the Jews is being claimed". It showed the photograph of

a 4 year old boy, whose father, named SOLNIK, used to be an old salesman of stamps in Paris and lived now in Jerusalem. He claimed his son to be direct descendant from King David and thus eligible for the empty Palestinian throne, vacant for the last 3,000 years. The "future king" (?) was born June 22, 1943 and it is a symbol because it is actually opposite in the Zodiac to December 25th, Christmas, the Holiday of the Christ who was denied as a Messiah 2,000 years ago. (See Figure)

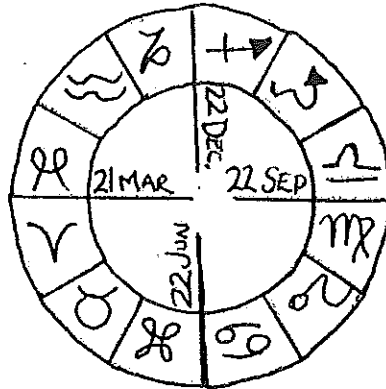

Equinoxes and Solstices

The natal chart of young Solnik may contain the potential to be elevated to power, nevertheless we do not have the exact hour of birth which is indispensable when one wishes to be precise. The name is very interesting, too.

It is interesting to note that the result of the multiplication of 142857 always provided us with an important historical judaic date; we decided to look into it to find a future important date. For instance, 142857 multiplied by 4 = 571428, therefore the year 5714 of the judaic era, which corresponds to 1953 of our calendar gives us a clue. This is how we came about to erect a chart for the skies of September 1953 (the beginning of the year 5714 of the Jewish calendar) and found the planets in the sky forming the Solomon's Star.

According to traditional interpretations these planetary positions announce the arrival of a Messiah, understood in a more human plane, in accordance with the age of materialistic concepts in which we are presently living. This may be a State leader or a Prophet who would bring great changes and reunite the children of Israel.

Let us study the number 571428. We have already seen how the planets in the heavenly map follow the order of: Jupiter 5, Saturn 7, Moon 1, Mercury 4, Mars 2, Venus 8. Let us see how the name of the young descendant of David corresponds to such planets:

- S - Shin in Hebrew, and according to Esdras it means arrow, or in a sense, the sign of Sagittarius which traditional Astrology mentions as ruled by Jupiter (the first planet symbolizing the number 5).

- O - The IOD is the key to the Hebrew Cabala. It is also the Egyptian Uroborous, the unity of all Matter. The snake Apophis, symbol of darkness and the battle of darkness and Light (Sun). Corresponds to Saturn, related to battles and death.
- L - The LAMED in Hebrew corresponds to the Moon.
- N - Mercury. It is NOUN, meaning fruit, the intellect.
- I - Mars. This letter follows the Great of Major Arcanes and corresponds to Aries, the home of Mars.
- K - It is the 19th letter of the Hebrew alphabet. In alchemic cryptography it is represented by a small circle with a cross underneath, which is also the symbol for Venus.

Here is how the study of the name corresponds with the numbers and planets:

5	7	1	4	2	8
Jupiter	Saturn	Moon	Mercury	Mars	Venus
S	O	L	N	I	K

The occultists will be able to analyze it in depth, and therefore I shall abstain from making any more commentary.

## ATLANTIS

Critias said, "Listen, Socrates, to an admirable and true story as told by Solon."

Plato is the first one who officially mentions a disappeared continent, as follows:

"Listen, Socrates, to an admirable and true story as told by Solon, the highest among the Seven Wisemen. He had told it several times to my grandfather Critias, who himself told me about it in my childhood, as part of the happenings which had occurred in our country. So many calamities have occurred throughout long centuries that the human being has almost forgotten this important happening."

"He used to bring up an outstanding one. Saias' father had mentioned it to Solon as follows: 'Before the last deluge which had such a destructive effect, our village, Oh Solon, used to flourish with power and wealth...It is known that it endured the several attacks from a great number of enemies who originated from the banks of the Atlantic Ocean, simultaneously invading Europe and Asia, because in those days our sea was so easy to cross. At the entrance, in the corner now called Hercules' Columns, there was a piece of land larger than Libia and Asia put together. Therefore it was possible to visit other islands nearby and from there go to the lands across and next to the ocean. In this corner there used to be a port and a small gulf. This area was a true ocean and the land a true continent, called ATLANTIS. Princes with formidable power reigned throughout it and several other islands. They also controlled lands which we now own, and had conquered a third of the world, called Libia, up to Egypt, and on the other side they had occupied part of Europe on the western part close to the Tirren Sea."

The aforementioned quotation clearly states there used to be a continent, before the deluge, which extended from the point of "Hercules' Columns" (Strait of Gibraltar) to the other side of the trip. This statement confirms the existence of several successive deluges, the last of which took place 2,168 years before Christ.

The quote continues referring to wars: "immediately after a terrible earthquake there came a deluge and it poured rain continuously for 'one day and one night', the earth opened up and swallowed your warriors, together with the enemies, and thus ATLANTIS disappeared in such a vortex. That is the reason why this ocean cannot be navigated; the mud and shallowness make it insurmountable. Such is the report from Socrates, which my grandfather says was heard from Solon."

After studying Critias' dialogue, one knows that this war occurred 9,000 years ago. It is also evident that the Mediterranean Sea had a different length than it does now (it says that it was easy to cross) and there was a continent to which one could arrive by crossing a line of islands. The weather in Atlantis was southerly and allowed two crops per year. In the north it was mountainous, and in the plains was the capital of the Atlanteans, which kept going down to sea-level. There are many more details which could be given but we do not want to expand more on these now.

The Atlantis Continent extended from Cape Verde up to Venezuela. Before Atlantis, there was another continent which united Senegal with Brazil and which also became submerged. The Sahara Desert is the vestige of the waters which separated the Atlantean Continent from its colonies. These colonies ran from North Africa to Egypt. The Sahara Desert is the ancient bed of an ancient sea. If one studies the chain of Islands called Azores, Canaries, and Cape Verde, one sees that all are part of a general sedimentary base, thus proving to be the vestiges of a submerged continent. The flora and fauna of these Islands is surprisingly similar to those on the American continent. The mollusk found in these Islands is also analogous to the European fossils of the Tertiary Age. More than 15 different families of them have been found both on the coasts of Senegal and the Antilles. It would be impossible to think that they were dragged there by an underground current because embryo life would have been endangered.

The Popol Vuh, (a sacred book of Central America) tells of an immigration of peoples from far away in the East. It is possible that they could have arrived on the American Continent by land, travelling from island to island, while a later immigration had to go around to cross an area of the ocean already overflowed.

In brief, all stories tell of the existence of the continent of Atlantis and it can be proven scientifically through a good number of theories.

Let us study times past under different Ages analysing the Races. Within each racial type one finds spiritual types which bring about the true evolution of the material races. For example, the three children of Adam and Eve are the spiritual types which appear in each one of the four races, materially speaking.

The races appear in the following order: white, yellow, black, and red (the green race is the same as the yellow but in its origins it used to be green olive color). These races appeared in a particular continent with a special flora and fauna, their own language and tradition. The end of a race comes about by the sinking of a continent, thereby allowing a new race to appear.

The white race was the original one and has hardly left any footprints. Supposedly, this primordial race inhabited the Northern Continent which sank to be followed by the Southern.

SIMILARITY IN WRITINGS

𐤀 𐤁 𐤂 𐤃 𐤄 𐤅 𐤆 𐤇 𐤈 𐤉

Several Signs of the Atlanteans

CORRESPONDENCES:

𐤀	𐤁	𐤂	𐤃	𐤄	𐤅	𐤆	𐤇	𐤈	𐤉
Chinese man	U	J	L	X.	N	Ancient Greek	Moab	Ancient Sanskrit	Aztec

𐤀	𐤁	𐤂	𐤃	𐤄	𐤅	𐤆	𐤇	𐤈	𐤉
F.	W.	N.	S.	A.	E.	DZ.	R.	C.	

HEBREW-----SAMARITAN

𐤀	𐤁	𐤂	𐤃	𐤄	𐤅	𐤆	𐤇	𐤈
TSE.	KA.	JE.	YA.		JA.	KA.	QUA.	

VATTAN

𐤀	𐤁	𐤂	𐤃	𐤄	𐤅	𐤆	𐤇	𐤈
Fruit	Passage	Mouth	Ox	Life	Country	Ear	House	Perfection

CHINESE

OTHER DETAILS:

𐤀	𐤁	𐤂	𐤃	𐤄	𐤅	𐤆	𐤇	𐤈
---	---	---	---	---	---	---	---	---

Idea of the Light of Knowledge

𐤀	𐤁	𐤂	𐤃	𐤄	𐤅	𐤆	𐤇	𐤈
Tibet	(Chinese and Egyptian)	Idea of Knowledge Chinese, Aztec and Egyptian				The civiliziers "Yoni" Mexico, Egypt, India		

𐤀 𐤁 𐤂

Greatness Omnipotence

Egypt, China, India

This is only part of a theory which chooses the white man as the first one and native to the North Pole where the first species of human being appeared.

The yellow race inhabited a Continent in the northern part of the Pacific Ocean. After it sank, the eastern plains of the Asiatic Continent appeared and the Aleutian Islands were left as its vestiges.

The black race comes from Lemuria, the vestiges of which run from New Zealand to Madagascar. After it sank, the plains of South Africa appeared.

The red race (copper) inhabited what is now the Atlantic Ocean and after it sank, the American Continent appeared, a long time ago.

The duration of each race lasts approximately 13,000 years (half time of an equinoctial precession). One Day for some and one Night for others, a cycle of 25,920 years (the great Platonic Year) which is the time required by our star to retrograde upon its same point of departure.

Atlantis disappeared approximately 11,000 years B.C. The Atlanteans were the carriers of the Tradition of the Patriarchs transmitted in the Adamic writings. Legend says that they had arrived to such a height in their knowledge, difficult for us to even imagine, especially in regards to sound magic, and in their ambition to condense solar energy their pride allowed them to be dragged into terrible catastrophes through which their lands disappeared and thus the American Continent appeared. Those who could escape were able to settle in their African colonies.

The red or copper race had attained a high degree of civilization and had colonies all the way to Ethiopia. Some think that Egyptian civilization originated with them.

The inclination of the axis of the Earth changed the inclination of the axis of the Terrestrial pole, which had been pointing towards the Pleides (the daughters of Atlas) a constellation referred to as "the Atlantis" located next to Vega. Another name given to them is that of "the Xibaldaides" when quoted in the American traditions which refer to cataclysms.

Peoples of the red race from the Continent of Atlantis have common characteristics with peoples in the American Continent. Egyptian civilization is similar to the Mexican, Peruvian, and Central American. The Etruscans, Iberians, Guanches, Berberiscs, Arabs, Vascs and peoples from the American continent have great similarities which denote common origins and race.

If the succession of races occur with cataclysms such as dluges and other perturbation, what awaits present day humanity?



Eastern Indian peoples seriously speak of the disappearance of Europe, supposedly flooded by the oceans, sixty years after changes occur in the beds of the Atlantic Ocean. The whole eastern Atlantic area is particularly volcanic and the extreme corner is the site for the Azore, Madera, Canary and Cape Verde Islands which are always experiencing "tremors".

Microscopic studies have proven similarities between rocks from high altitudes and rocks taken from the depths of the ocean with edges in the form of knives. Apparently, the eruption which generated the flow of lava is produced both in the heights above oceans as in the depths of oceans. Lava in the ocean disintegrates after approximately 15,000 years.

The bed of the Atlantic Ocean supposedly was above sea-level 15,000 years ago. Twenty-three years from now (14) certain peaks will be elevated to more than 3,500 meters (2½ miles).

In brief, adding the 11,000 years before Atlantis disappeared to the 2,000 of our Age, we have 13,000 which marks the racial disappearance predicted in India.

There are many different theories and prophecies, be these from "mediums", astrological sources, or the ones found in the Egyptian Pyramids, but all agree in one thing, namely, that a new race is to appear and there are many signs preparing its birth.

There is a theory which says that if all continents would unite and form one, its center would be Jerusalem....Great Prophets refer to the NEW JERUSALEM, a new Center of the World!...Once again the prediction of a huge catastrophe which would change the entire globe!

It is important then to know which areas are destined to disappear in order to do what Nostradamus calls "preventions so as not to be devoured by the waters, else people will die under the roar of the ocean and its currents".

Nevertheless, the INITIATES, who knew the causal destiny of humanity will participate with justice and efficiency in this transcendental moment of History. The ONLY Great Truth shall be made known on the planet because the INITIATES always appear at a certain moment of human history and we need to trust in them and be prepared for the Great Final Judgment.

---

(14) Geological data is as follows: In 1950 it was established that the bed of the Atlantic was MOVING constantly, and it varied according to the movements of the Earth as well as of the Earth's axis (since 1948, the New Age brought about a different inclination to our planet) which could very well slow down a predicted catastrophe. On the other hand, atomic experiments (numberless bombs thrown in the ocean) have radiations which might also stop the emersion of submarine peaks.

## THE TEMPLARS

Quisque Structor  
qui debitis et idoneitate  
quae requiruntur

Among the numerous groups belonging to the Universal Great Brotherhood (always referred to as the White Brotherhood because of the White Robes worn by their members), there is one that was famous in the history of the world: the Templars.

The knight Templars also used the name of the Knights of Christ, because some of Godofredo de Bouillon's friends remained near the Master Patriarch of Jerusalem and had decided to dedicate themselves to the defense of the pilgrims who visited the Sacred Places and to the defense of the Holy Tomb.

Godofredo Bisol, A. de Saint Agnan, Pagan de Montdidie, Gondemar, Rossal, Andre de Montbernard, and Hugo the First Count of Champagne joined Hugo de Payns. These French Knights were encouraged by the Patriarch himself, who received their first oath. This was 1118 and the community was officially formed then.

Due to the fact that Baldwin II, King of Jerusalem, (1131) gave them lodging near his palace in a spot designated as the place of the ancient Temple of Solomon, these Knights adopted the name of Templars (Templarii).

Pope Honorio III confirmed the rules of this Order that contained 72 articles, and thus the founding of the Fraters Militiae Templi took place.

The rules stipulate the giving of a white cape with a hood to the Knights with a special ritual. The Novice is kneeling and the Elder Brothers sing the Psalm Ecce quam bonum and pronounce the prayer consecrated by the ritual of the investiture of the Order. (See Revelations, Ch. III, Vers. 18; Ch. IV, Vers. 4; Ch. VI, Vers. 2; Ch. VIII, Vers. 13; Ch. XIX, Vers. 14).

Little by little the order grows and already in their first reunion in Jerusalem, there were 300 Knights present. The 27th of April of the year 1147 the Brothers attended the Chapter of Paris in large numbers, because the House of the Temple was not only the Center of the Order of the Templars in France but the Headquarters of the entire Order. This house was founded the year 1140 under the name "Villanueva of the Temple".

In 1291, the Templars, the last Christians who were defending the Crusaders, were defeated at St. John of Acre by the Saracenes and ended up leaving the Asiatic continent to seek refuge on the Island of Cyprus.

From 1296 to 1304 the Order was drawn into the conflicts between Pope Boniface VIII and Phillippe the Handsome. The death of Pope Boniface VIII, the 11th of October 1303, put an end to the quarrel.

The King Phillippe the Handsome was in a difficult financial situation, and only the Templars agreed to lend him large sums of money. The king was not very eager to repay this loan to them and this eventually caused him to become interested in making the renowned Order disappear.

Having absolute power in electing the new Pope, King Phillippe the Handsome chose among the most ambitious prelates knowing that no one would object or refuse him. It was the Archbishop of Burdeaux whom Phillippe the Handsome chose. Bertrand du Got, a friend from his childhood, was elected Pope the 5th of June, 1305 under the name Clement V.

Phillippe the Handsome requested the Pope to see to the destruction of the Order. This request was facilitated by the difficulties that the Templars had suffered in the East during the second half of the XIII century, forcing them to return to their vast dominions in Europe and mainly to France, their native land.

In 1306 when the mob wanted to kill him, the king obtained asylum in the house of the Templars in Paris, a fact that seemed to intensify the king's anger for the famous cavalry which he swore to exterminate.

In 1298 the Venerable Monk Gaudini died and, by unanimous vote, the Templars brough Jacques de Molay to the leadership as Grand Master. He was getting ready to recoup the places lost by the Brothers of the Cavalry, when the Pope called him to France to arrange for the reunion of the Templar and Hospitalary Order (the latter founded in 1099 by G. Toxm), an arrangement which did not succeed.

The Templars followed their Grand Master and they dispersed among the numerous chapters that the Order had in many countries. The Templars had 9,000 chapters in Europe by the end of the XIII century. 15,000 Knights belonged in France and the Order was distributed in 17 provinces scattered in a great number of isolated places.

The "crime" of the Order was its autonomy, for its regulations recognized only God as their Superior.

One day Phillippe the Handsome requested membership in the Order but in spite of his efforts, he could not obtain it because the Constitution of the Order was in no sense political. To revenge what he considered an insult, (as well as the fact that his self-esteem had been injured by having been saved in 1306 when the

Templars could have abandoned him to his own fate, yet nevertheless protected him from the popular furor that was aroused by his decree changing the value of money), Phillipe the Handsome decided by the beginning of September 1307 to put an end to the Templars.

From his own residence in the Abbacy of St. Maclou de Pontoise, the king sent letters written with his own hand to the provinces ordering the arrest of all the Templars on the same day and at dawn.

In spite of everything, at the eve of his arrest, the 12th of October 1307, Jacques d Molay attended, in the presence of the king, the funerals of Catherine de Courtenay, granddaughter of Baldwin II (1217-1272) Emperor of Constantinople and the second wife of Charles de Valois. The next day, (October 13, 1307) the Grand Master, Jacques de Molay, was arrested with 140 of his Knights in the Temple while the same day Phillipe the Handsome settled himself in a appropriate place to supervise the inventory of his captor's estate.

The trial immediately started with all the well-known horrors: false denunciations, confessions forced out with torture, violence, etc., prolonging the torments for four years, that is, from October 13, 1307 to April 13, 1311.

On March 19, 1313, in the atrium of the Notre Dame Church in Paris, the Grand Master of the Templars appeared on the stand after having refused the freedom that was offered to him if he revealed what was asked of him. By rejecting their offers with disdain, he chose death with a pure and just conscience rather than the selling of his spirit. That same night declaring his innocence and his Order's, Jacques de Molay died in the flames, displaying an energy and a resignation worthy of his virtue.

When they were going to tie him to the stake and tie his hands behind his back to light the bonfire, he said: "At least allow me to join my hands if the time has come. I am going to die now, and God knows it is unjust, but I have the conviction that my death will be revenged. I would like you to turn my face to Jesus Christ for I was his loyal servant."

Here lays in brief form the history of this semi-religious and Chivalric Order that lasted 200 years and which continued in silence since the members that escaped torture scattered around and formed small occult groups transmitting the true teachings of the Order.

In fact, history has presented the Templars in their usual exoteric form even though the Institution had an even more elevated Mission than the defense of the pilgrims: the Transmission of the INITIATIC TRADITION. —

*handing down orally of stories, beliefs, customs, etc. established generations ago.*  
*to bring into practice or use*  
*introduce by first doing or using*  
*to admit as a member into a fraternal club, etc.*  
*to send or pass on from the person of the sender to the receiver*  
*esp. across interview*  
*to send out*  
*to hand down to others by reciting to pass on*

In addition to the Initiates in the Order, a large number of people who served and had no initiatic degree were part of it. There also existed an esoteric Hierarchy of Masters, who being the representatives of the Universal Great Brotherhood, placed their traditional treasures only in the hands of experts. These Grand Masters of the Order of the Temple were:

Hugo de Payan (in 1118), born February the 9th, 1070 in the Mahum Castle in Ardeche, France and who died in 1136, mourned by all the Christians in Palestine. Robert the Bourguignon succeeded him, and it is assured that the purity of his behavior as well as his high lineage made him no less illustrious. Evrad de Barrés was Grand Master in 1147, followed by Bernard de Tramerlai in 1149, who died with all the Knights that accompanied him in 1153. Bertrand de Blanquefort, Grand Master in 1153, was succeeded by Phillipe de Naplouse in 1168, who abdicated in 1171, and was succeeded by Odon de Saint Amand. Armand de Toroge was Grand Master in 1179, succeeded by Terric in 1184. Gerard de Riderfort in 1188 was killed in a battle against Soladin. Robert de Sable was Grand Master in 1191, succeeded by Gilbert Horal in 1196, Phiipe de Plessies in 1201, William de Chartès in 1217, Peter de Montaigne in 1219, Armand de Perigord in 1233, William de Sonac in 1247, killed in battle when St. Louis was made prisoner, Renaud de Vichiers in 1250, and Thomas Beraut in 1256. Guichard de Baujeu, Grand Master in 1273, died within the walls of the Villa de Acre when it was besieged by Kalil Ascraft, Sultan of Egypt. The Monk Gaudini, Grand Master in 1291, escaped with 10 Knights (out of 500) and died in 1298. It was then that Jacques-Bernard de Molay succeeded him.

These 22 Grand Masters of the Order of the Temple make us think that nothing occurs randomly in an Initiatic Order, as this Institution had precisely 22 representatives as a kabalistic symbol. We know that the 22 letters of the Hebrew alphabet are not simply grammatical symbols, but that they respond to well-defined secret meanings. These 22 keys are the general esoteric base of occultism.

Isn't it interesting to see the last and twenty-second Grand Master characterized by the number 13? It was the 13th of October that Jacques de Molay was arrested and the trial lasted just until the 13th of October of the year 1311; it was the 19th of March of 1313 when he went to the scaffold, and the numerical reduction of 19 is 1 plus 9, that is, 10 plus 3 (3rd month), equal to 13, of the year 13! It is notable that for the Order of the Temple events revolve around the number 13.

Some have taken the year 1314 as the execution date, a great mistake, because in the year 1314 Easter fell on the 7th of April. The Pope and the king had died: one on April 20, 1314 and the other on Friday the 29th of November of the same year. According to the mistake of these chroniclers, the Venerable Jacques de Molay would have died after Clement the V and Phillipe the Handsome.

On the other hand, we know that Master Jacques de Molay, before dying, made a prediction summoning the Pope and the king in front of the Divine Tribunal: "The end of your lives is close; the Pope Clement will die within 40 days, and the King Phillippe the Handsome within a year. You will appear before God's Tribunal... very soon." This prophecy was fulfilled exactly.

The 13 is the intimate of 26, the divine essence and the divine existence, IHOH, the I AM. The radical 13 is IG in Etruscan, in Veda, in Sanskrit, etc..., and it is read as AG, meaning: I, whose ordinary number is 10, and G whose ordinary number is 3, giving birth to IGnis, AGNI, AGiosh. Within the inversion of GA and GI one finds in Hebrew The Splendor of the sephirot, with the repetition of the Supreme Crown, the 3 Intellectual Splendors. In Veda this is the Organic Potential of the Agni and also the Universal Penetration, namely: p:: s:: of the 18o. and p::p:: of the 25o. of the R:: E:: A:: and A::.

CROSS OF THE EIGHT BEATITUDES, a heraldic parchment drawn in red (fire of action) that although not being an emblem of the Knight Templars, it is a Key to wisdom expressed in the characters of a secret alphabet, which represents, with its four converging triangles, the disposition of constructive forces towards a central point. Its important symbolism embodies the 4 elements, the 4 gospels, the 4 great virtues, the 4 letters of the divine name Iod-He-Vau-He, etc.

*perfect blessedness  
or happiness*

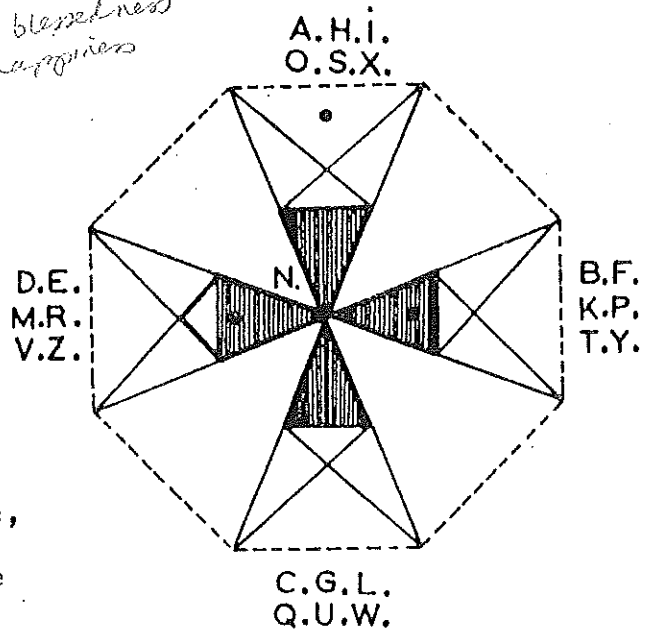

- This key contains the alphabet of the adjoint illustration.
- A, B, C, D: in normal order (solar retrogradation or inverted swastica)
- E, F, G, H: like making the sign of the cross in reverse
- I, K, L, M: incorrect, inverted solar zone, and starting from the top
- O, P, Q, R: correct swastica
- S, T, U, V: continuation
- W, X, Y, Z: second way of making the sign of the cross starting from the bottom, but not in a malefic way.

N: is the important letter (as it is well-known in the Qabbala) and everything gathers around the central letter N (Nazareth) that is written like an "X", which is a kind of St. Andrews Cross, Greek symbol of Christ (Xristos). In Greek the letter KHI is also represented by an X, initial of the 3 terms of the Grand Alchemist Work: Kone (Gold), Krusos (crucible) and Kronos (time), triple manifestation of the Great Hermetic labor.

SECRET ALPHABET OF THE TEMPLARS

∇	A	▽	H	◁	P	◊	W
◁	B	◊	I	△	Q	◊	X
∧	C	◊	K	▷	R	◊	Y
∨	D	◊	L	▽	S	◊	Z
▷	E	◊	M	◁	T		
◁	F	X	N	△	U		
△	G	∇	O	▷	V		



Mysterious Templar inscription found on the walls of the prison in Kenilworth's castle, inscribed by the Knight Templars, prisoners, in order to transmit it to others.

One cannot truly believe it was a coincidence that Huges de Payan gathered his first 7 Knights in a septenary number (as the 7 planets, 7 notes of music, 7 states of matter, 7 basic colors of the Rainbow in the Sky, etc.) for an Order that would have 22 Grand Masters. These numbers 7 and 22 make us think of the traditional equation for PI, which was transmitted in an uncertain way by Euclid. We have always defended the issue of 3.1428571... resulting from the division of 22 (the arcanae of life) by 7 (the death of a state, the days of the week)...Mathematically, the number 3.141592742... is more exact for the "squareness of the circle", but in terms of symbolism the first number is more traditional.

The 72 articles of the rules of the Order are significant for students of occultism, for they are related to the 72 verses of David and the 72 geniis of the Kabala. (It is said that these are completely esoteric and that the Bible hardly contains a half, altered or omitted.)

We will also mention, in passing, about the name of the Venerable Master Jacobus Bergundus Molay whose initials are very symbolic for the first three degrees of Freemasonry. Also, one can verify in the date of his death the symbol of the rounds of battery proper to the 33rd degree, characterized by the year 5312 of the masonic calendar, for the 19th of March of 1313 still corresponded to the initiatic year of 5312, since the year 5313 was going to start beginning with the 21st of March 1313. The time of his martyrdom is still now commemorated by the S:.. G:.. I:.. G:.. of the Supreme Council of F:.. M:..

Jhesu would have not chosen 12 Apostles and 72 disciples for no reason. He planned his action within the descended human substance when choosing the symbols of the 12 signs of the Zodiac, the 72 semi-decanates and the 360 degrees of the circle (360 affiliated). He was only fulfilling his own logical, harmonious, and organic law, as the Creative Word.

A final word about the Science of the 22, which is Science in all its rigor, as is proclaimed by St. Paul in his first letter to the Corinthians: Chapter I, Vers. 7,8,9. The number 22 in Adamic letters is written Ka-ba, and if the letter LA is added (which means POWER), Power of the 22 (Ka-ba-la) is obtained, such is the famous ancient Kabala. When it is stated that the exact ethnology of this Hebrew word means tradition, it is understood as esoteric Tradition or Initiation.

This Falsapha (Arabic word which means philosophy) is the traditional chain that is orally transmitted among all the semitic peoples. The profane world rarely understands that the Templars had close similarities with the Moslems, since they were the link of union between East and West. Thus is explained the traces of Christian allegories in certain Arab authors, and the traces of Sufism in some Christian doctrines in the Middle Ages.



under any form it takes, we will say: "Tacawwuf". And likewise let us use in other languages the Hebrew or Arabic words in order to conserve in their native tongue the expression of the traditional forms, whatever they may be, as well as to find comparisons or similarities, without necessarily confusing historical circumstances, and without necessarily having to place them in opposition to each other. To make it clearer we will cite along these lines "JHESU", used to characterize the Essene Master, invested with a name that has the "H" of command (that is for certain found in the embroidered monograms on the chasuble of the priests and carved in the cup of chalices) and without the letter "S" at the end which would connect him to the Nordic tribes (the AS). Written in this form we find ourselves in face of the Initiate of the Southern Schools, even though, naturally, they are the same person.

There are several terminologies that will be interesting to study, offering a new horizon to the searcher of Light, like the Lumen of Lumine from St. Atanasio's Creed and Moses' Genesis.

In St. John's Revelation, Ch. VII, Vers. 1,2,3, and 6, 144,000 harps that scatter their chords throughout space symbolize the value equivalent to the 72 genii multiplied by the 2,000 years of an AGE.

In relation to the expression Real Art that is used in Masonry, we could notice the interesting similarity between the name of HeRMes and of HiRaM, which while having no common linguistic origin, nevertheless its constitution HRM does originate many of the varied studies about its forms and esoteric symbols.

We don't think it is necessary to explain the meaning of the three masonic dots which are equally employed by the Templars, as well as Solomon's Seal, and other symbols, not only used among Brotherhoods, but also in several Secret Societies or Initiatic Institutions.

It is very important to study the High Objective of this Tradition, and in particular that of the Templars; that, being like all Orders, keepers of Ancient Wisdom, radiates a grandiose purpose: an organization of the world where Christians, Jews and Moslems are hierarchically incorporated for the PEACE and Prosperity of the whole world.

In every moment of history there are Monastic Orders of Chivalry, and corporate Orders that are organized more or less secretly, using the same hieroglyphics (Albigens, Gibelines, Templars, Rosacrucians, etc.). It is also worth noting that simulataneously there arise new opposing movements who are against the defenders of Human Rights and of Traditional Civilization. These movements zealously defend their self-interests in order to force the partisans of pure Initiatic Tradition, of the true Light, to hide themselves and thereby be able to maintain a bandage covering the eyes of the ignorant.